



## Learning Activity #1:

# Build a Model of a Truss Bridge

## Overview of the Activity

In this learning activity, you will build a model truss bridge that has already been designed for you. When construction is complete, you will load the bridge to determine if it performs as its designer intended. With the load in place, you will be able to observe how the structure works—how the various structural members work together to carry the load safely and efficiently. And at the end of the project, you will save the model as evidence of your bridge-building skill. Don't break it! We will be using it again in subsequent learning activities.

## Why?

*Design* is the essence of engineering. The only way to truly appreciate the challenges and rewards of engineering is to actively engage in the creative process of design. So why, in this learning activity, will we devote considerable effort to building a bridge that has already been designed by someone else? It is true that building an existing design will not allow you to exercise a lot of creativity; nonetheless, this activity will provide you with valuable preparation for learning how to design a structure. Building an existing design will allow you to:

- Learn many key concepts about trusses and structural behavior that you'll use when you design your own bridge in Learning Activity #5.
- Familiarize with the engineering characteristics of a rather unique building material—cardboard from a manila file folder.
- Learn some special construction techniques appropriate for this material.
- Work with confidence, knowing that your bridge will carry the prescribed loading successfully, as long as you build the structure with care.
- Learn about the challenges faced by real-world construction contractors, who are often required to build structures that have been designed by someone else.

# Learning Objectives

As a result of this learning activity, you will be able to do the following:

- Explain what a *truss* is.
- Identify the major components of a truss bridge.
- Identify the types of truss bridges.
- Explain the following fundamental structural engineering concepts: *force, load, reaction, equilibrium, tension, compression, and strength*.
- Explain how a truss bridge works—how each individual component contributes to the ability of the entire structure to carry a load.
- Explain the roles of the four key players in the design-construction process—the *Owner, the Design Professional, the Constructor, and the Project Manager*.
- Explain how construction quality affects the performance of a structure.

## Information

### 1. Component Parts of a Truss Bridge

#### What is a Truss?

A **truss** is a structure composed of members connected together to form a rigid framework. **Members** are the load-carrying components of a structure. In most trusses, members are arranged in interconnected triangles, as shown below. Because of this configuration, truss members carry load primarily in **tension** and **compression**. (We'll discuss these terms in Section 3 below.) Because trusses are very strong for their weight, they are often used to span long distances. They have been used extensively in bridges since the early 19<sup>th</sup> century; however, truss bridges have become somewhat less common in recent years. Today trusses are often used in the roofs of buildings and stadiums, in towers, construction cranes, and many similar structures and machines.

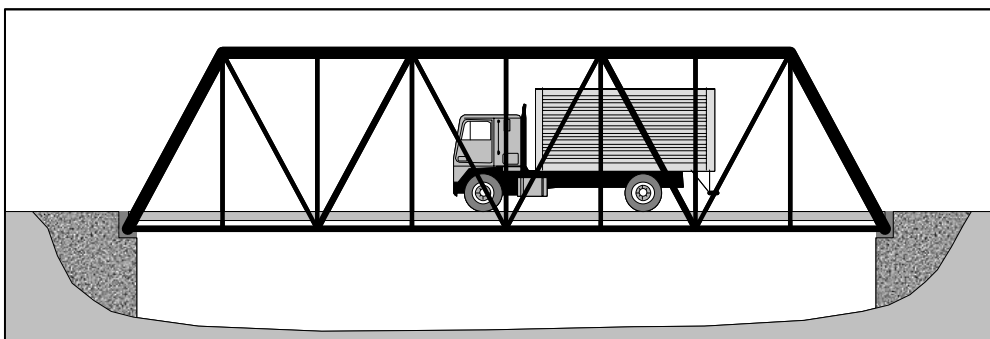

A typical truss bridge. Note that the structure is composed entirely of interconnected triangles.

Trusses, like all structures, are designed by civil engineers with special expertise in structural analysis and design. These men and women are called **structural engineers**.

#### Component Parts

The major components of a typical truss bridge are illustrated in the two diagrams below. The **elevation view** shows the bridge from the side. The **isometric view** is a three-dimensional representation of the structure. Note that certain members are *only* visible in the isometric view.

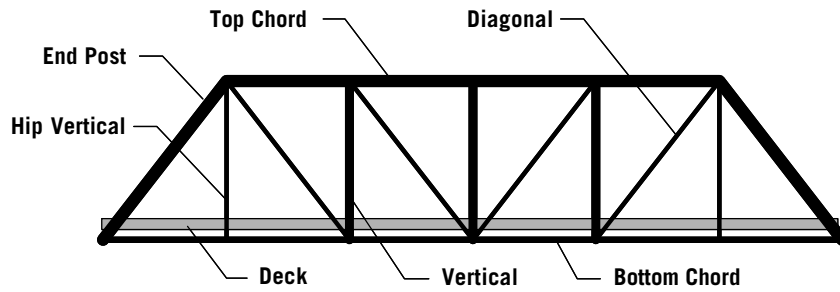

Component parts of a typical truss bridge - Elevation View

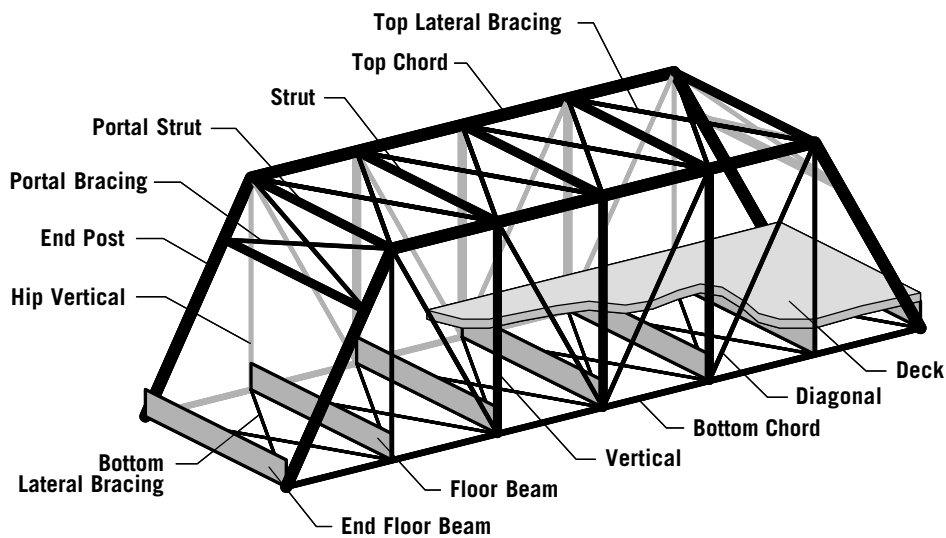

Component parts of a typical truss bridge - Isometric View <sup>1</sup>

The three-dimensional bridge structure has two main load-carrying trusses. Each truss is composed of a **top chord**, a **bottom chord**, and several **verticals** and **diagonals**. The two trusses are connected together by a series of transverse members—**struts**, **lateral bracing**, and **floor beams**.

In early truss bridges, all of these members would have been made of wood or iron. Today they are usually made of steel. Modern steel truss members are manufactured in a wide variety of shapes and sizes. A few common examples are shown on the following page. The model truss we will be building uses both **solid bars** and **hollow tubes**. When we load-test our model, we'll see why one truss often uses two different types of members.

<sup>1</sup> Based on "Truss Identification: Nomenclature," Historic American Engineering Record HAER T1-1, National Park Service, 1976.

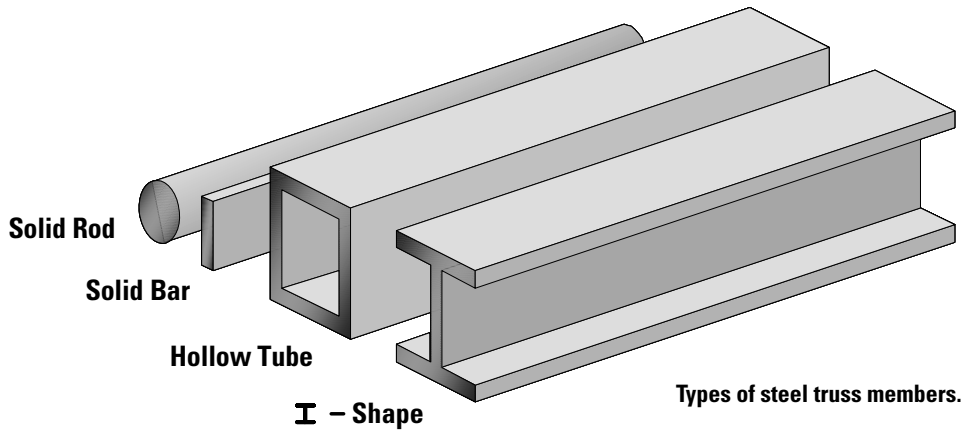

One major component of a truss bridge that is usually *not* made of steel is the **deck**—the flat surface between the two main trusses. (In the isometric drawing, only part of the deck is shown, so the structural members below it can be seen.) Bridge decks are usually made of concrete, but might also be built from wooden planks or steel grating. When vehicles or pedestrians cross a bridge, their weight is directly supported by the deck. The deck, in turn, is supported on the floor beams. The floor beams transmit the weight of the vehicles and pedestrians (and the weight of the deck) to the main trusses.

The truss drawings above do not show the **connections** that are used to join the structural members together. Even though the connections are not shown, they *are* important! They have a big influence on the ability of a structure to carry load. Indeed, inadequately designed connections have been the cause of several catastrophic structural failures in the U.S.<sup>2</sup>

There are two common types of structural connections used in trusses—**pinned connections** and **gusset plate connections**. Examples of each are shown in the photographs below. As the name suggests, the pinned connection uses a single large metal pin to connect two or more members together, much like the pin in a door hinge. In a gusset plate connection, members are joined together by one or two heavy metal **gusset plates**, which are attached to the individual members with rivets, bolts, or welds. Pinned connections were used extensively throughout the 19<sup>th</sup> century. Most modern bridges—including the model bridge we will be building here—use gusset plate connections.

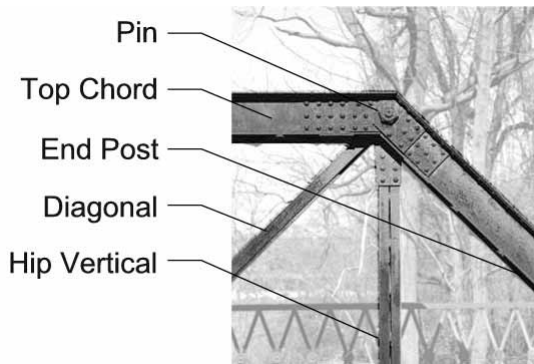

**Typical pinned connection.**

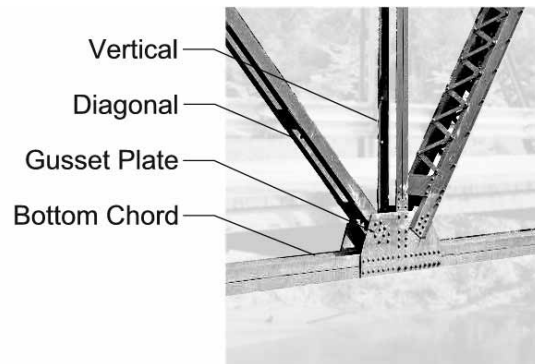

**Typical gusset plate connection**

Each of the bridge components described above has a specific purpose. All of the components work together to ensure that the bridge carries load safely and efficiently. In this learning activity, we will fabricate and assemble these various types of structural members and components, and we will observe how each one works.

<sup>2</sup> For more information on structural failures, see *Why Buildings Fall Down*, by Mario Savadori.

## Foundations

Every structure must be supported on a firm **foundation**, which distributes the weight of the structure to the soil or rock below it. Bridges use two different types of foundations. The ends of a bridge usually rest on **abutments**, which serve two functions simultaneously—they support the bridge and also hold back the soil that is filled in behind them. If the bridge requires additional support in the middle of the gap, one or more **piers** are used, as shown below. Abutments and piers are normally made of concrete.

All structural foundations are designed by civil engineers with special expertise in soils and foundations. These men and women are called **geotechnical engineers**.

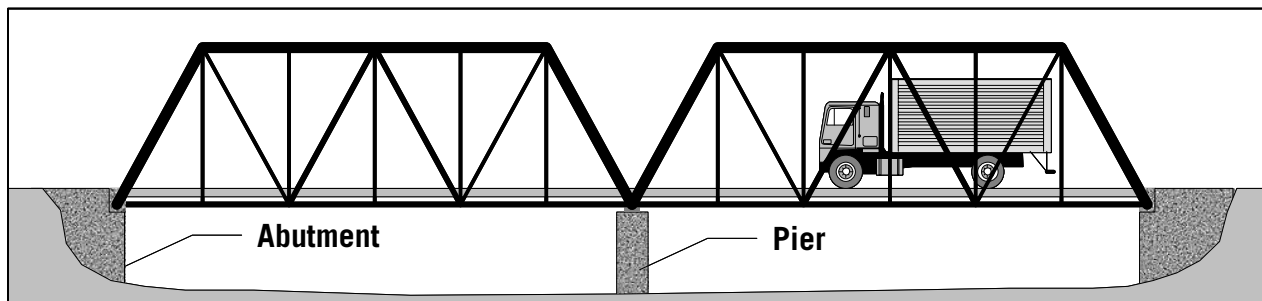

Types of bridge foundations.

# Q1

### Can you identify the component parts of a truss bridge?

Select any bridge pictured in the Gallery of Truss Bridges (Appendix A), and identify its major component parts—top and bottom chords, verticals, diagonals, floor beams, lateral bracing, struts, portal bracing, deck, abutments, and piers. (You will not be able to find every one of these components on every pictured bridge.)

## 2. Types of Truss Bridges

Truss bridges are grouped into three general categories, based on their deck location. If the deck is located at the level of the bottom chord, the bridge is called a **through truss**. A **pony truss** looks just like a through truss, except it is not as high and has no lateral bracing between the top chords. If the deck is located at the level of the top chord, the bridge is called a **deck truss**.

Trusses are also classified according to the geometric arrangement of their chords, verticals, and diagonals. The diagrams on the following page show 15 of the most common truss configurations, many of which were named for the 19<sup>th</sup> century engineers who developed them. On each diagram, the solid lines represent the main structural members in the truss. The dotted lines shown on some trusses represent supplemental members that may or may not be present on a particular bridge of this type. Designers sometimes use these lightweight diagonal members to more efficiently carry the weight of moving vehicles. The classification of a bridge is not affected by the presence or absence of these supplemental members.

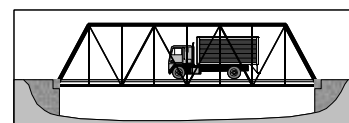

Through truss.

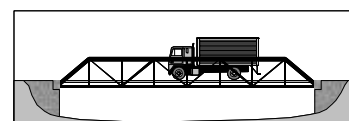

Pony truss.

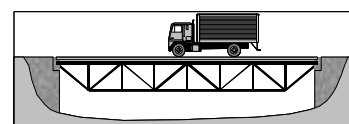

Deck truss.

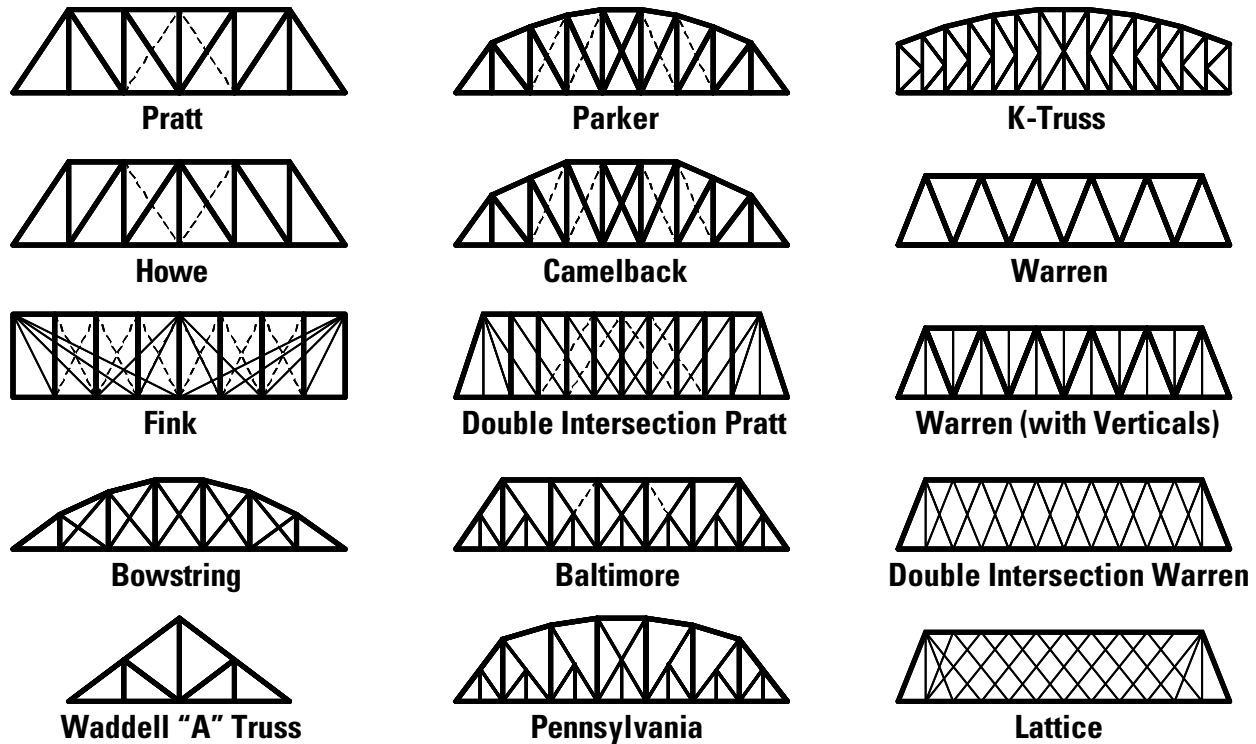

Common truss configurations.<sup>3</sup>

Note that all of these diagrams depict *through trusses*. Many of these configurations are also used in *deck trusses* and *pony trusses* as well.



### Can you identify the configuration of a truss bridge?

Identify the configuration of each bridge pictured in the Gallery of Truss Bridges (Appendix A). Also note whether each bridge is a through truss, deck truss, or pony truss.

## 3. How a Structure Carries Load

One of the most important learning objectives of this project is to understand how a truss bridge carries load. But what exactly is a “load,” and what does it mean for a structure to “carry a load?” To answer these questions, we will need to introduce (or perhaps review) some basic concepts from physics.

### Forces

Much of structural engineering deals, in some way, with the concept of *force*. A **force** is simply a push or a pull applied to an object. A force always has both *magnitude* and *direction*. When a truck crosses a bridge, it exerts a force on the bridge. The magnitude of the force is the weight of the truck, and the direction of the force is downward. Mathematically, we represent a force as a **vector**. By definition, a vector is a quantity that

<sup>3</sup>Based on “Truss Identification: Bridge Types,” Historic American Engineering Record HAER T1-1, National Park Service, 1976.

has both magnitude and direction. To show a force on a picture or diagram, we normally represent it as an arrow (which shows the direction) and a magnitude (in units of force, such as pounds or newtons), like this:



In structural engineering, it is useful to distinguish between three different kinds of forces—**loads**, **reactions**, and **internal member forces**.

**Lloads**

To illustrate what loads, reactions, and internal member forces are, let’s do a simple experiment. Find a nutcracker like the one shown below, and tie the ends of the handles together with a piece of string. Ensure that the string is taut. You have just built a simple truss composed of three members—the two handles and the string. Now put the ends of the nutcracker on a smooth, flat surface, and press down on the center hinge. You are applying a **load** to the nutcracker truss. A load is simply a force applied to a structure.

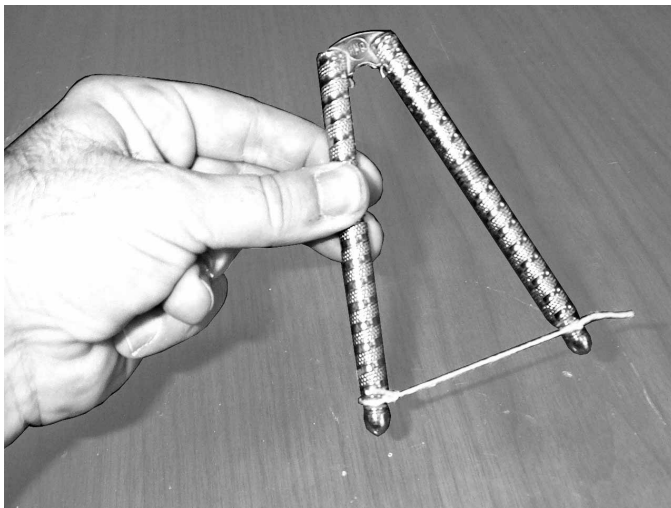

A simple 3-member truss made from a nutcracker.

Applying a load to the nutcracker truss.

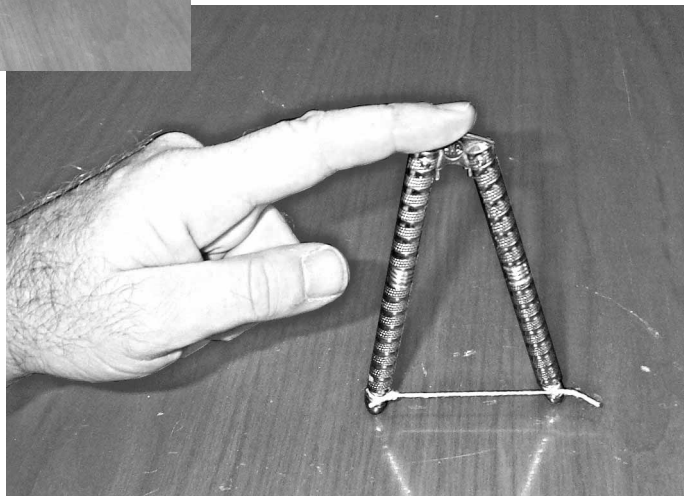

Actual bridges are subjected to many different kinds of loads, including the following:

- Weight of the vehicles and pedestrians crossing the bridge
- Weight of the bridge itself
- Weight of the asphalt or concrete road surface
- Wind pushing sideways on the structure
- Weight of snow, ice, or rainwater
- Forces caused by earthquakes

In designing a bridge, the structural engineer must consider the effects of all these loads, including cases where two or more different kinds of loads might occur at the same time.

## Reactions

Newton's First Law—one of the basic principles of physics—states that *an object at rest will remain at rest, provided it is not subjected to an unbalanced force*. In other words, if an object is not moving, then the total force acting on it must be zero. When you apply a downward force to your nutcracker truss, it *does not* move; thus, according to Newton's First Law, the total force on the truss must be zero. But how can that be? Suppose you push *down* on the nutcracker with a force of 10 newtons. The nutcracker does not move, because the table pushes back *upward* with a force of 10 newtons. In this particular example, because the structure touches the table at two points, the table actually pushes upward with two forces, each with a magnitude of 5 newtons, as shown below. The structure is said to be in **equilibrium**, because the total upward force equals the total downward force. A structure that is not moving *must* be in equilibrium. Mathematically, the vector sum of all forces acting on the structure is zero. If we assume that the upward direction is positive, then

$$+ 5 + 5 - 10 = 0$$

In our example, the two upward forces are called **reactions**. Reactions are forces developed at the supports of a structure, to keep the structure in equilibrium. **Supports** are the points where the structure is physically in contact with its surroundings. On our nutcracker truss, the supports are located at the ends of the handles, where the nutcracker touches the table. On an actual bridge, the supports are located at the **abutments** or **piers**. (See Section 1 above.)

Geotechnical engineers are particularly interested in the reactions of a structure, because the foundations must be designed to carry these forces safely and efficiently.

## Internal Member Forces

When you apply *external* loads to a structure, *external* reactions occur at the supports. But *internal* forces are also developed within each structural member. In a truss, these internal member forces will always be either **tension** or **compression**. A member in tension is being stretched, like the rubber band in the picture below. Tension force tends to make a member longer.

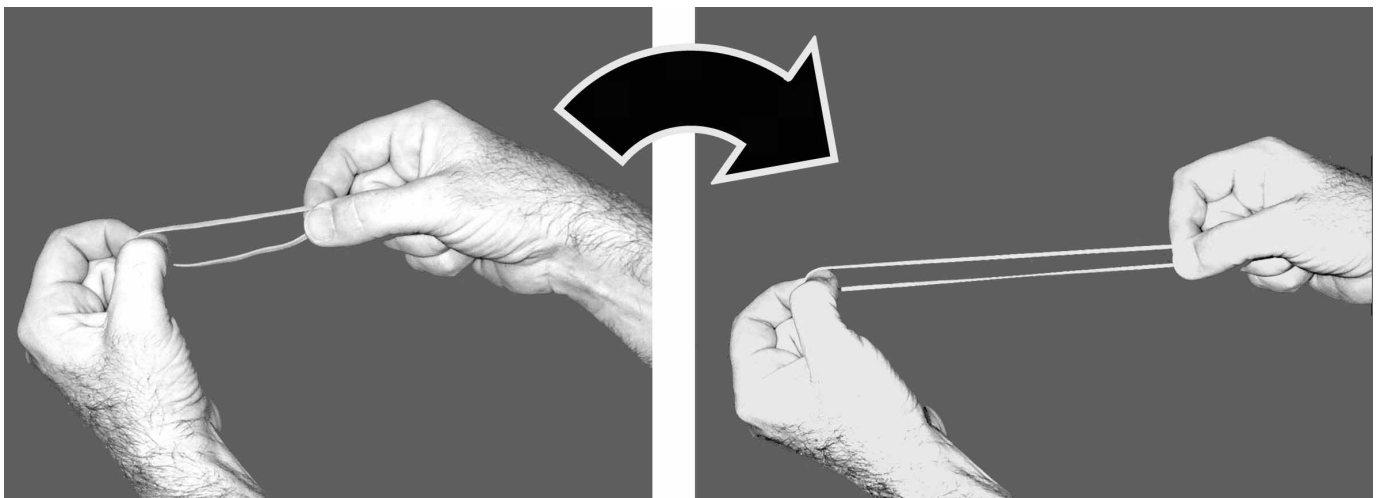

**Tension is an internal force that tends to make a member longer.**

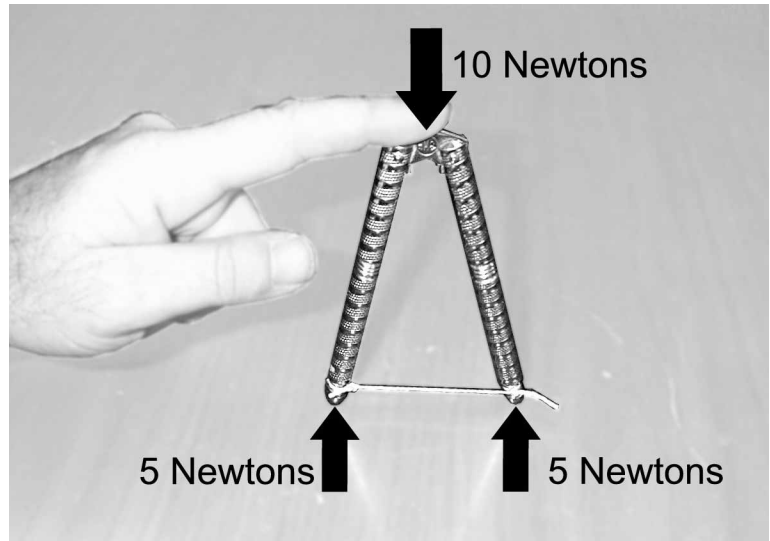

**The two 5-newton reactions keep the nutcracker truss in equilibrium with the 10-newton load.**



A member in compression is being squashed, like the block of foam in the picture below. Compression force makes a member shorter.

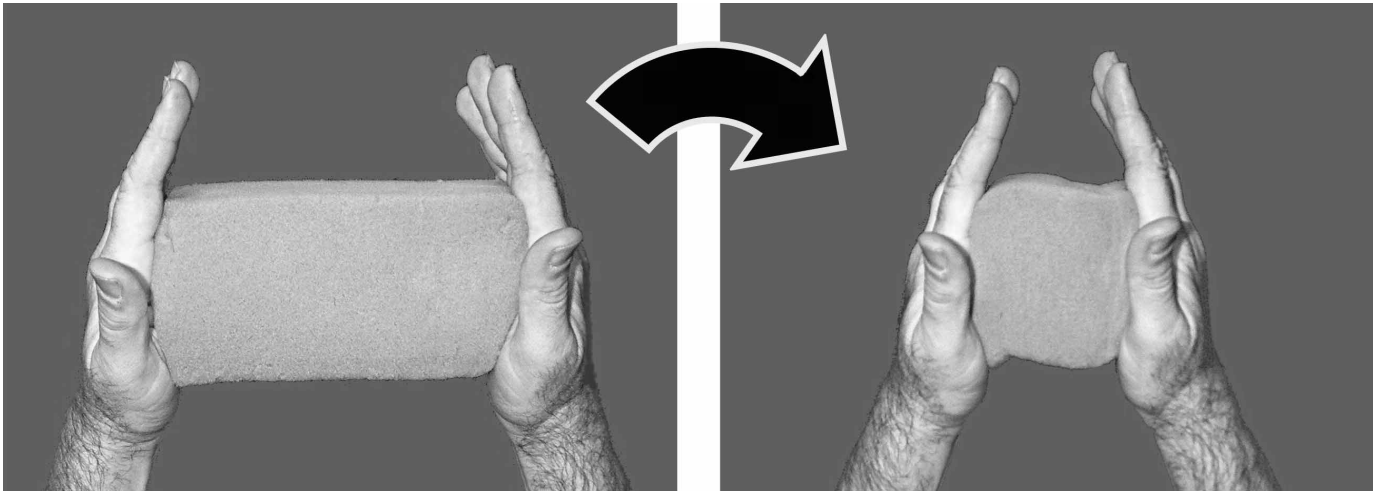

**Compression is an internal force that tends to make a member shorter.**

Tension and compression are among the most important concepts in structural engineering. A renowned engineer and author named Mario Salvadori once wrote,

*All structures, in a one-family house or a skyscraper, in an arch or a suspension bridge, in a large dome or a small flat roof, are always either in tension or compression. Structures can only pull or push. If you understand how tension and compression work, you understand why structures stand up.*

In our nutcracker truss example, the two handles are in compression, while the string is in tension, as shown here. If you push down hard enough on the nutcracker, you can actually see the string stretching in tension. Unfortunately, you can't see the nutcracker handles shortening in compression—steel is so stiff that the shortening of the handles is too small to be seen with the naked eye. But the handles actually do get shorter!

Like loads and reactions, internal member forces must obey the laws of physics. Internal forces must be in equilibrium with each other *and* with the loads and reactions. By applying the concept of equilibrium and some relatively simple math, we can actually calculate the internal force in every member of a truss. We'll see how to do this Learning Activity #3.

**Strength**

Let's return once again to our nutcracker truss example. As we have already seen, if you press down on the hinge at the top of the structure, a tension force is developed in the string. If you press down harder (that is, if you increase the load), the tension force in the string increases. If you are very strong, or if the string is very weak, you should be able to apply a downward force that is large enough to break the string.

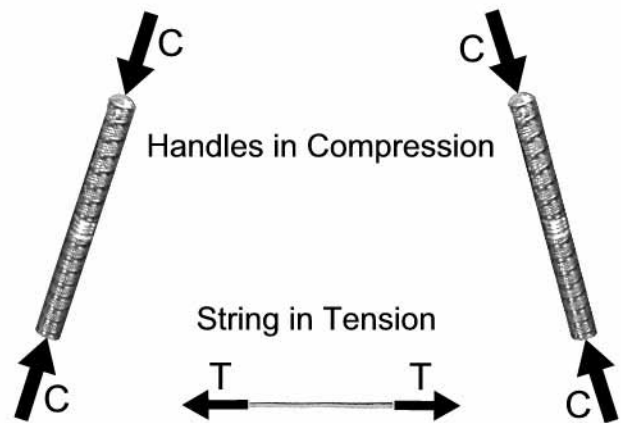

**Tension and compression in the nutcracker truss.**

What causes the string to break? The string breaks *when its internal member force becomes larger than its strength*. This observation leads us to two closely related definitions:

- (1) The **strength** of a structural component is the largest internal force the component can experience before it fails.
- (2) **Failure** occurs when the internal force in a structural component becomes larger than its strength.

If you have ever bought fishing line, you might have noticed the words “100 pound test” or something similar on the label. “100 pound test” means that the line is guaranteed not to fail, as long as the internal force in the line is less than 100 pounds. To put this in structural engineering terms, the *strength* of the line is 100 pounds.<sup>4</sup>

### How Does a Structure Carry Load?

Having discussed loads, reactions, internal member forces, and strength, we can now answer the important question posed at the beginning of this section: *what does it mean for a structure to carry load?*

In this learning activity, you will build and load-test a model bridge. If you build the bridge well, it will carry the load successfully, and you will have an opportunity to observe how the structure works.

*When you apply a load to a structure, internal forces—tension and compression—occur in each member. If the strength is greater than the internal force for every member in the structure, then the structure will carry the load successfully.*

## 4. The Project Team: Key Players and Contributions

Building a model bridge is a great way to start learning about the process used to design and construct actual structures. But before we can fully understand this process, we need to meet the key players in the design-construction process and learn about how they contribute to its ultimate product—a completed structure or facility. This section applies equally well to *any* civil engineering project, not just to a bridge project.

### The Project Team

Major construction projects are always performed by a **project team**, composed of many different specialists. Each member of the team contributes unique capabilities or resources to the project, and all must work together to make the project successful. The team has four key players—the Owner, the Design Professional, the Constructor, and the Project Manager—organized as shown in the diagram on the following page.

<sup>4</sup>Actually, the true strength of the line is probably somewhat higher than 100 pounds. In order to guarantee a strength of 100 pounds, the manufacturer would normally design the line to be somewhat stronger than that—say 150 pounds. Small variations in the dimensions or material characteristics of the line will always occur during manufacturing. By building in some extra strength, the manufacturer ensures that the “100-pound guarantee” will not be violated. This extra margin of error is called a factor of safety. We will discuss the factor of safety at the end of this learning activity, and we will actually calculate it in Learning Activity #3.

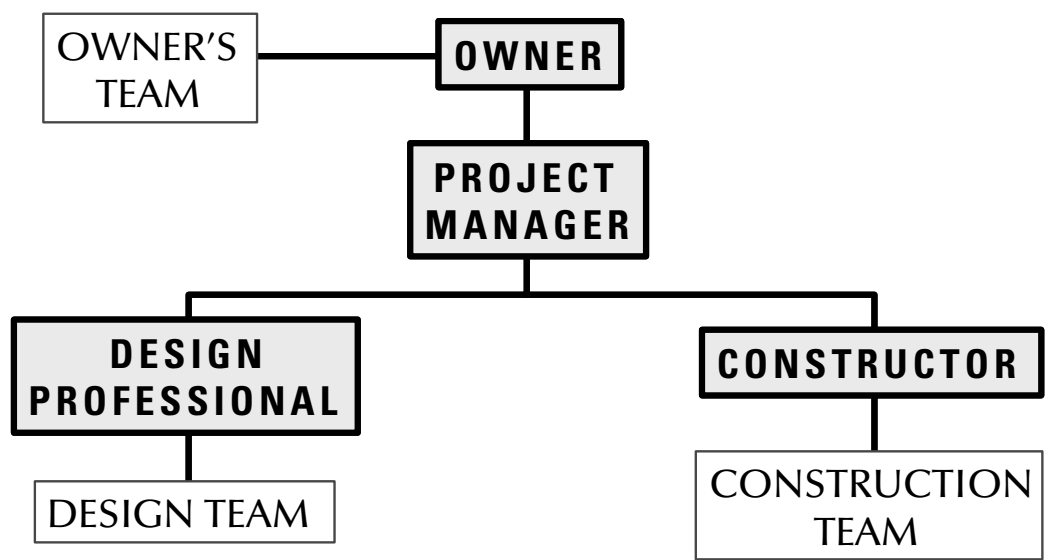

The organization of the Project Team <sup>5</sup>

### The Owner

The **Owner** is the person or organization that initiates the project and ultimately will take ownership of the facility after it is built. The Owner might be a private developer, a corporation, a public agency, a municipal government, or simply an individual. Regardless of who the Owner is, he or she makes four vitally important contributions to the project:

- **Identify the need for a new facility.** For example, a state Department of Transportation might identify the need for a new highway bridge across a river. Without the need, there can be no project; thus identifying the need is probably the Owner's most important contribution.
- **Provide funding to pay for the project.** The Owner provides the money or arranges for financing to fund the project. Often the Owner also provides the land on which the new facility will be built.
- **Put together the Project Team.** The Owner selects and hires the Design Professional and the Project Manager, usually based on their professional qualifications and experience. The Owner does not necessarily select the Constructor but always decides *how* the Constructor will be chosen. Often this is done by a competitive bidding process. No matter how the Design Professional, Contractor, and Project Manager are selected, they work for the Owner—either as employees or by contract.
- **Establish the design requirements.** The **design requirements** include **functional requirements**, **aesthetic requirements**, and any **constraints** that will affect the design or construction of the facility. The Owner often develops the design requirements in close coordination with the Design Professional. On a bridge project, for example, the Owner probably knows generally what purpose the proposed structure will serve—what kind of traffic it will carry, what body of water it will cross, how much money is available to build the bridge, and when it must be completed. The Owner might have some general ideas about how the structure should look—perhaps the appearance of the bridge needs to be consistent with other nearby structures. But the Owner probably does not know what type of bridge will be best for the chosen site, which environmental regulations and safety standards will govern the design, or exactly how much traffic the new bridge must be able to handle. These sorts of technical requirements are provided by a technical expert—the Design Professional.

To perform these functions, the Owner usually has a team of experts to assist with specialized functions such as financial management, real estate, legal assistance, insurance, and facilities management. These specialists—often members of the Owner's own staff—are shown as the **Owner's Team** on the organization chart above.

<sup>5</sup> Quality in the Constructed Product: A Guide for Owners, Designers, and Constructors, American Society of Civil Engineers Manual No. 73, ASCE, New York, 1990.

## The Design Professional

The **Design Professional** is responsible for conceiving, planning, and providing a high-quality design solution to the Owner. The Design Professional may be an engineer or an architect, depending on the nature of the project. In either case, the Design Professional rarely has sufficient expertise to perform all aspects of the design. He or she puts together and supervises a team of specialists called the Design Team. The composition of this team will vary depending on the nature of the project, but it is likely to include engineers from many different disciplines—structural, geotechnical, transportation, environmental, mechanical, and electrical—as well as surveyors, draftsmen, and other technicians. The Design Team might be composed entirely of employees from a single, full-service engineering company, or it might include consultants hired for just one particular project.

The Design Professional's principal contribution to the project is a set of **plans and specifications**. *Plans* are drawings, and *specifications* are highly detailed written descriptions of every aspect of the project, including all *quality standards* the completed facility must meet. Plans and specifications often include detailed lists of structural members and components. These lists are called **schedules**. For example, structural drawings often include a Column Schedule and a Beam Schedule. We will be working with several such schedules in this learning activity.

Often the Design Professional has little direct involvement in the construction process. For this reason, the plans and specifications must be sufficiently clear, unambiguous, and thorough that a Constructor *who has had little or no involvement with the design* can build the facility correctly. Engineers must know how to write well and must be able to communicate effectively with drawings.

## The Constructor

The **Constructor** is responsible for planning, managing, and performing the construction of a facility, after it has been designed. The Constructor is usually a **construction contractor**—a company that assumes full responsibility for building the facility, under the terms of a formal contract with the Owner. Like the Design Professional, the Constructor assembles and supervises a team of specialists with skills appropriate for the project. When these specialists are hired by the construction contractor, they are called **subcontractors**. On a typical project, the subcontractors might include carpenters, masons, ironworkers, electricians, material suppliers, steel fabricators, equipment operators, surveyors, material testing companies, quality control inspectors, and many others.

The Constructor's contribution to the project is the completed facility. A constructed facility is generally considered to be successful if it is delivered (1) on time, (2) within budget, and (3) to the standard of quality spelled out in the plans and specifications. These three criteria suggest that the Constructor must do much more than just construct. He or she must also (1) develop and manage an accurate project schedule, (2) carefully manage project costs and payments, and (3) perform effective quality control. **Quality control** is the process of routinely inspecting and testing materials and workmanship on a project and taking corrective action when problems are found. Effective quality control happens when the Constructor monitors the work *continuously*, rather than waiting until the end of the project, when it might be too late to correct mistakes.

## The Project Manager

The **Project Manager** has overall responsibility for managing both the design and construction of the facility. The Project Manager represents the owner and looks after the Owner's interests on all aspects of the project, to include scheduling, financial management, and construction quality. For buildings, bridges, and other infrastructure projects, the Project Manager is usually a civil engineer. He or she might be an employee of the Owner or a consultant hired for the specific project. Because the Constructor is rarely involved in the design phase of a project, and the Design Professional is often minimally involved in the construction phase, the Project Manager often must provide management continuity from project initiation through completion.

## Your Role in this Project

During this learning activity, you will serve primarily as the Constructor. On an actual project, the Constructor often has little or no involvement in the design process and only receives the plans and specifications after the design is complete; thus, your role as the Constructor in this project is actually quite authentic.

You'll play other roles in subsequent learning activities.

# The Learning Activity

## The Problem

### The Need

Just outside the small town of Hauptville, New York, Grant Road crosses Union Creek via a beautiful old 19th Century Pratt truss bridge similar to the one shown here. Recently, the Town Engineer determined that the structure is no longer safe for modern truck traffic and must be replaced. Because of its historic value, the old bridge will be disassembled, moved to a nearby public park, and rebuilt as a pedestrian bridge. A new highway bridge for Grant Road must be built on the existing site.

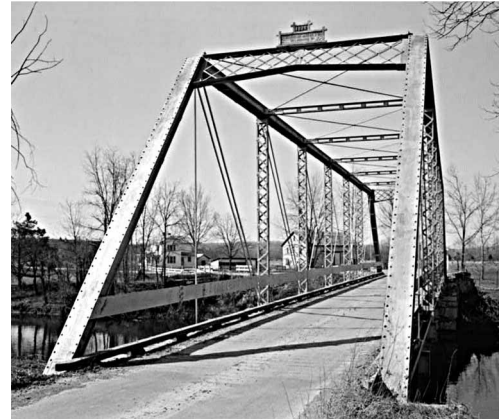

### Design Requirements

The Owner for this project is the Town of Hauptville. Several months ago, the Town Council selected Thayer Associates, a respected local engineering firm, as the Design Professional for this project. The Hauptville Town Engineer worked closely with civil engineers from Thayer Associates to develop three functional requirements for the bridge:

- The new bridge must be constructed on the abutments from the old structure. These existing supports are 24 meters apart.  
*[Our 1/40 scale model bridge will actually have a span of 60 centimeters.]*
- The bridge must carry two lanes of traffic.  
*[Our model bridge must have a roadway width of at least 9 centimeters and at least 9 centimeters of overhead clearance above the deck.]*
- The bridge must meet the structural safety requirements of the AASHTO bridge design code.<sup>6</sup>  
*[Our model bridge must carry a “traffic load” consisting of a 5 kilogram mass placed on the structure at mid-span.]*

The Town Council also added an important **aesthetic requirement**. To preserve the town’s historical character, the new Grant Road Bridge should look similar to the old one—a Pratt through truss. The old bridge was made of wrought iron, but the Town Engineer has decided that the new structure will be safer and more practical if it is made of steel.

*[For our model, steel will be represented by cardboard from manila file folders.]*

### The Design

Based on these design requirements, a team of engineers from Thayer Associates has developed **plans and specifications** for the new Grant Road Bridge over Union Creek. The plans and specifications include a structural drawing, isometric drawings of two typical connections, a schedule of truss members, a schedule of connections, and full-scale shop drawings of the structure.

<sup>6</sup> AASHTO is the American Association of State Highway and Transportation Officials, the organization that develops and publishes standard design specifications for bridges in the United States.

## Structural Drawing

The structural drawing of the new Grant Road Bridge is designated as Drawing S-1 and is provided on page 1-16. The drawing includes a side elevation, a front elevation, and a plan view. Note that every connection in the structure is designated with a letter—A through N for one main truss and A' through N' for the other. These letters are used to identify the members and gusset plates.

## Typical Connections

The two isometric drawings below are typical gusset-plate connections found at the top and bottom chords of the main trusses. These drawings illustrate the types of structural members used throughout the Grant Road bridge—hollow tubes for the top chords and verticals; doubled bars for the bottom chords and diagonals. The drawings also show how two gusset plates are used at each connection to hold all of the structural members together. The drawings do not show lateral bracing, struts, or floor beams, which have been omitted for clarity.

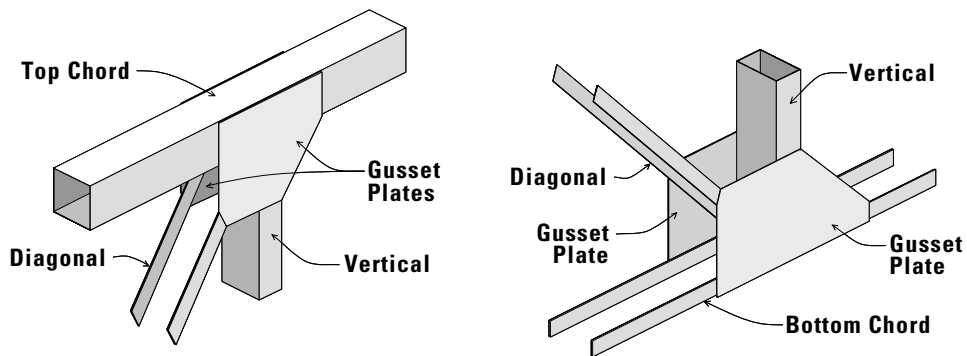

Typical top chord and bottom chord connections for the Grant Road Bridge.

## Schedule of Truss Members

The Schedule of Truss Members identifies every member required to build the bridge. Note that each member is identified by the two letters corresponding to its endpoints. For example, Member AD is a segment of the bottom chord that goes from Connection A to Connection D.

Component	Members	Type	Approx. Length	# Req'd
Bottom Chords	AD, DG, A'D', D'G'	4mm bar (double)	30cm	8
Diagonals	CI, DJ, DL, EM C'I', D'J', D'L', E'M'	4mm bar (double)	15cm	16
Verticals	BI, FM, B'I', F'M'	4mm bar (double)	11cm	8
Top Lateral Bracing	I'J', I'J', J'K', J'K', K'L', K' L, LM', L'M	4mm bar (single)	12cm	8
Portal Bracing	HI', H'I, MN', M'N	4mm bar (single)	10cm	4
Top Chords	IK, KM, I'K', K'M'	10mm x 10mm tube	21cm	4
End Posts	AI, GM, A'I', G'M'	10mm x 10mm tube	17cm	4
Verticals	CJ, DK, EL, C'J', D'K', E'L'	6mm x 10mm tube	12 cm	6
Top Struts	HH', II', JJ', KK', LL', MM', NN'	6mm x 6mm tube	9cm	7
Floor Beams	BB', CC', DD', EE', FF'	6mm x 15mm tube	10cm	5
Floor Beams	AA', GC'	28mm x 13mm angle	11cm	2

For this model, a member designated as a 4mm bar is actually a 4mm-wide strip of cardboard. The designation 6mm x 10mm refers to a hollow tube measuring 6mm by 10mm. The lengths shown in the schedule are approximate.

## Full-scale Shop Drawings

A full-scale layout drawing of the main trusses (Drawing SD-1) is provided along with this book. This drawing will be used to assemble the main trusses. A full-scale layout drawing of the gusset plates (Drawing SD-2) is also provided on page 1-17. This drawing shows exactly half of the gusset plates required for the bridge.

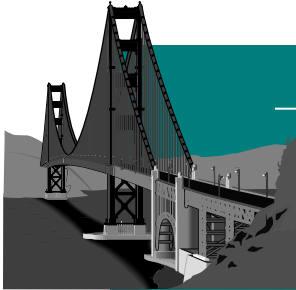

### On an Actual Bridge Project

#### What are shop drawings?

Shop drawings are detailed drawings of every component that will be part of the completed structure. These drawings are normally prepared by the Constructor and approved by the Design Professional.

## Schedule of Gusset Plates

The Schedule of Gusset Plates designates the gusset plates that will be used for each truss connection in the bridge. The numbers in the “Gusset Plate” column are from Drawing SD-2. The letters in the “Connections” column are from the structural drawing, Drawing S-1.

Gusset Plate	Connections	# Req'd
1	A, A', G, G'	8
2	B, B', F, F'	8
3	C, C', E, E'	8
4	D, D'	4
5	I, I', M, M'	8
6	J, J', L, L'	8
7	K, K'	4
8	I, I', M, M' (top)	4
9	J, J', K, K', L, L' (top)	6

## Your Job

Your construction company has been selected as the Constructor for the Grant Road Bridge project. Your job is to fabricate and construct the Grant Road Bridge, as specified in the Thayer Associates design. As Constructor, you are responsible for completing the project on time, within budget, and to the level of quality specified in the plans and specifications.

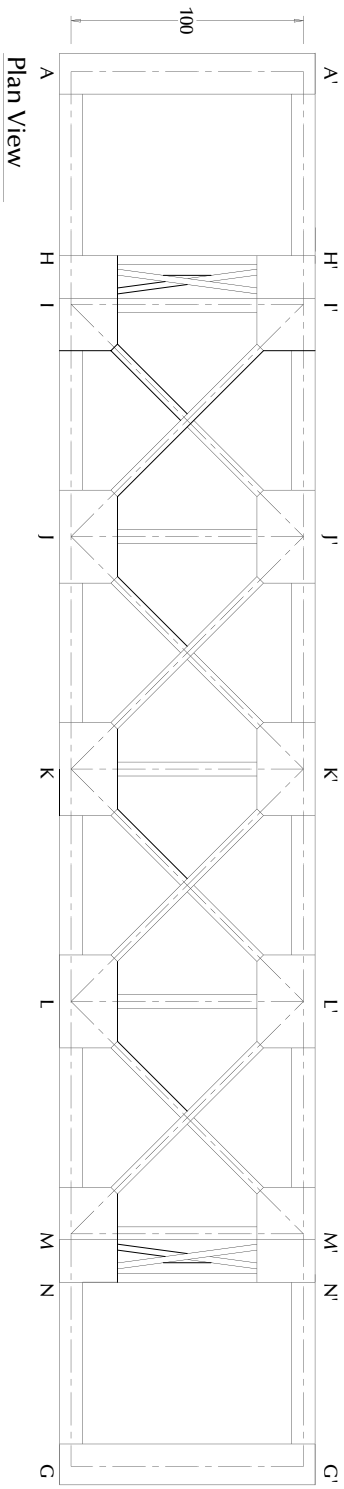



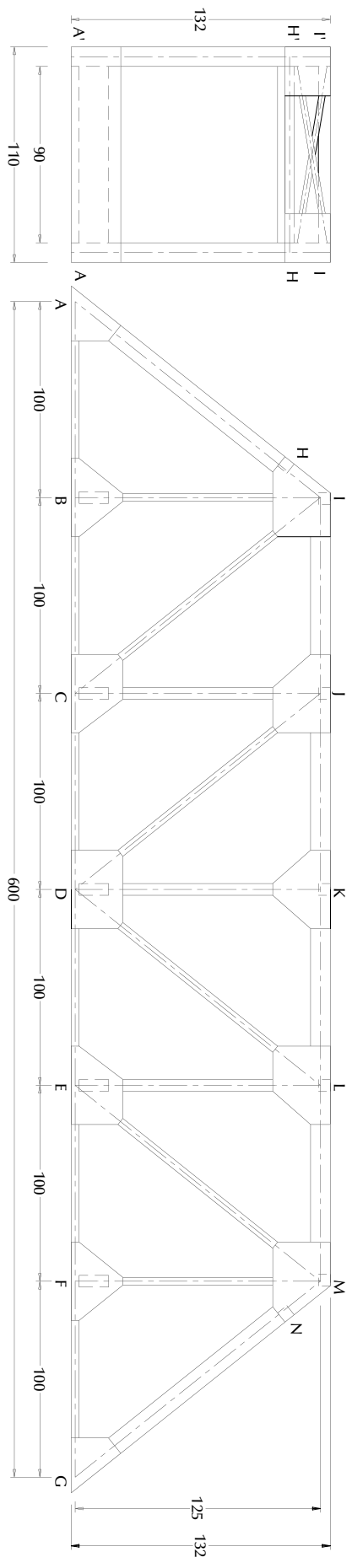

Plan View



Side Elevation

Front Elevation

- Notes:
1. All dimensions are in millimeters.
  2. All structural members and gusset plates are made from standard file folder material.
  3. See Schedule of Truss Members for specific member sizes.

Thayer Associates, Inc. Architects & Engineers		HAUPTVILLE, NEW YORK <b>GRANT ROAD BRIDGE</b> <b>OVER UNION CREEK</b>	
Designed by: 	Reviewed by: 	Date: NOVEMBER 10, 2000	Sheet Reference Number: <b>S-1</b>
Drawn by: 	Approved by: 		
Checked by: 			



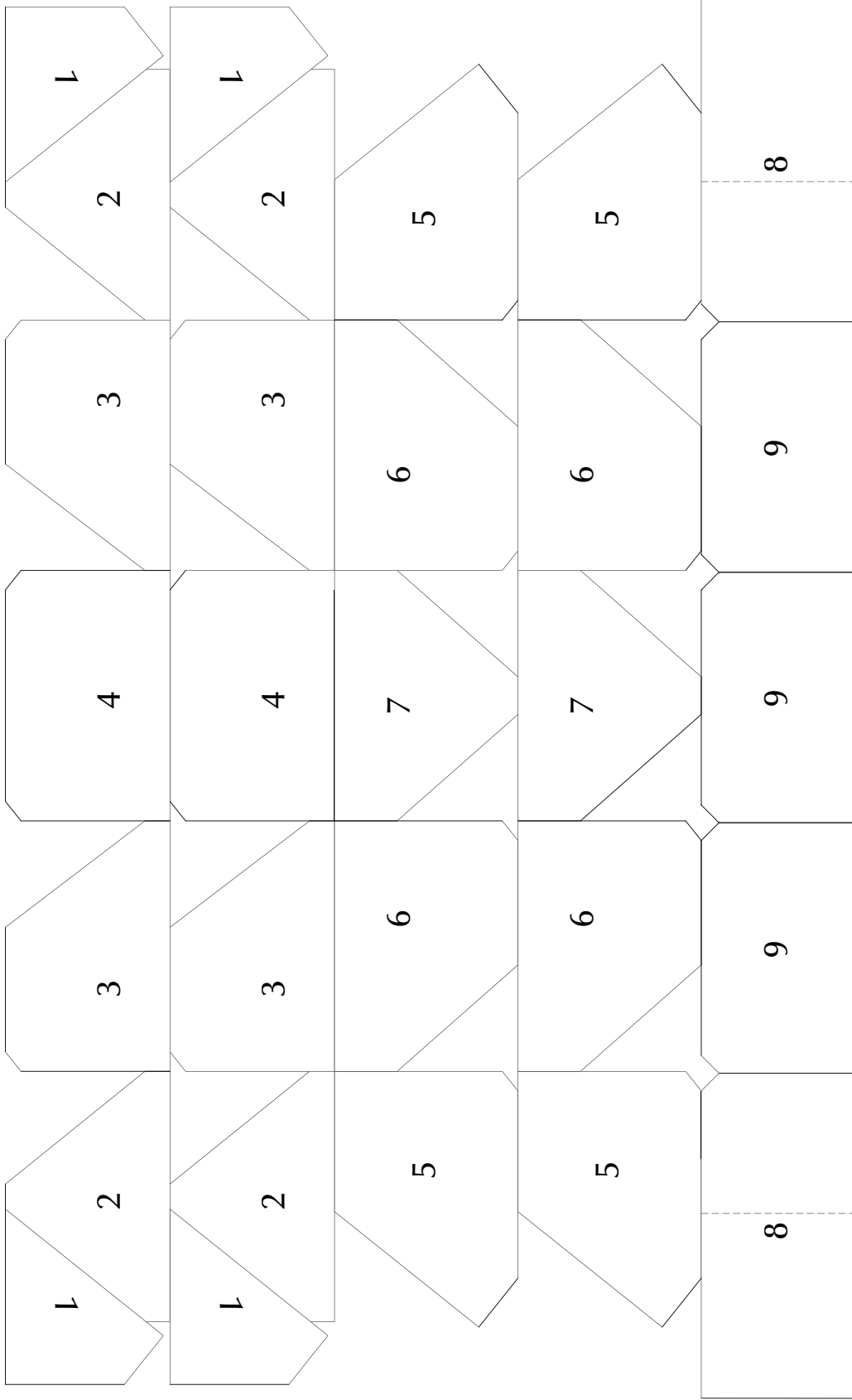

**Notes:**

1. All gusset plates are shown full scale.
2. This layout shows exactly half the number of gusset plates required for the bridge.
3. See the Schedule of Gusset Plates for the location of each plate.

Thayer Associates, Inc. Architects & Engineers		GRANT ROAD BRIDGE <b>GUSSET PLATE LAYOUT</b>	
Designed by:	<i>[Signature]</i>	Reviewed by:	<i>[Signature]</i>
Drawn by:	<i>[Signature]</i>	Date:	NOVEMBER 10, 2000
Checked by:	<i>[Signature]</i>	Sheet Reference Number:	<b>SD-2</b>

## The Plan

Congratulations on your selection as the Constructor for the Grant Road Bridge project! You have received the plans and specifications, and the Owner has given you the **notice to proceed**—an official authorization to start work on the project.

At the start of any construction project, the Constructor's first priority is to develop a detailed plan for building the facility. For this project, our construction management plan is relatively simple. It consists of the following six major steps, which should be performed in sequence:

- Obtain the necessary supplies and tools.
- Prefabricate the structural members and connections.
- Set up the construction site.
- Build the structure.
- Perform a quality control inspection.
- Put the bridge into service.

Put on your hard hat and your steel-tipped boots. It's time to get to work!

### On an Actual Bridge Project

#### Safety comes first.

A construction site can be a very dangerous place.

Everyone on the site is responsible for ensuring that the work gets done without serious injury or loss of life. The Design Professional must ensure that the structure can be built safely. The Constructor must ensure that every worker has the necessary safety equipment and that everyone on the site follows appropriate safety procedures. The Project Manager oversees the safety of the entire project. Getting a project done can never be as important as the life of one worker.

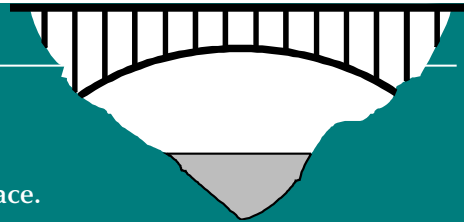

## Obtain the Necessary Supplies and Tools

To build the Grant Road Bridge, you will need the supplies and tools shown below. In addition, you'll need the full-size bridge plans that were included with this book.

- 3 standard manila file folders
- A building board made of cork or soft wood, measuring at least 45cm by 60cm.
- Wax paper
- Pins
- Small hammer
- Sharp pair of scissors
- Sharp hobby knife or single-edge razor blade
- Metal ruler or wooden ruler with a metal edge
- Ball-point pen
- Yellow wood glue
- Rubber cement

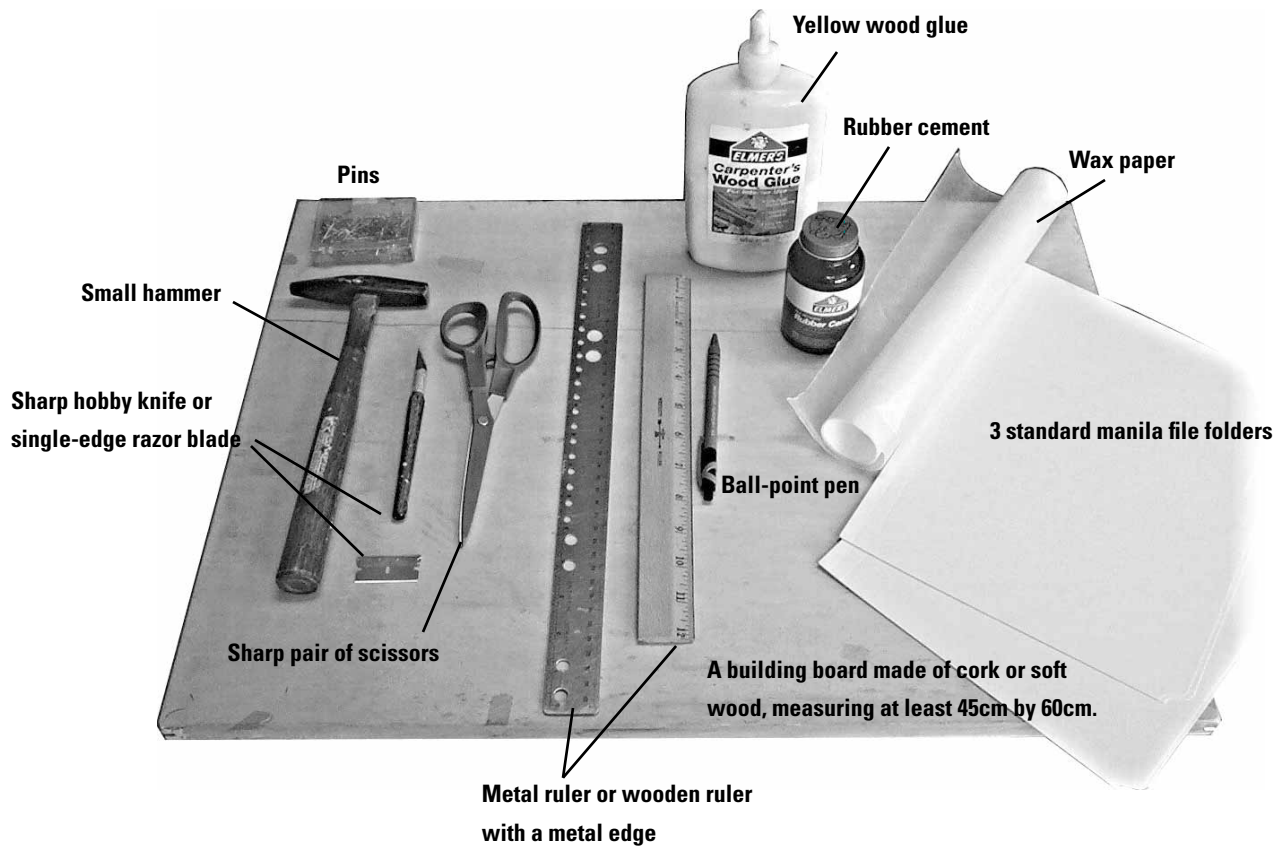

Some of the layout work will be easier if you use a draftsman's T-square and a drawing board. You'll also need a metric scale to weigh the books that we will be using to load-test the completed structure.

## Prefabricate the Structural Members and Connections

### Prefabricate the Bars

The bottom chords, diagonals, and hip verticals specified in the Schedule of Truss Members are all 4mm-wide bars—actually strips of cardboard sliced from a manila file folder. If you are using a standard 30cm-wide file folder, you'll need to slice 30 strips to make all of these members. Here's how to do it:

1) Using a ruler and a pen, carefully measure and draw 31 parallel lines exactly 4mm apart. Draw the lines parallel to the longer dimension of the folder, so that each line is 30cm long. (You can draw these lines more easily and more precisely if you use a T-square and a drawing board. Step 4 shows how the T-square is used.)

2) Place the marked file folder on your building board, and use a sharp knife and a metal ruler to cut along each line. Don't press too hard, or you'll have trouble making a straight cut. It will probably take two or three passes with the knife to cut all the way through the cardboard. (You could also use a scissors for this job, but you would find it much more difficult to make straight cuts.)

Don't cut the strips to length at this time. You'll do this when you build the trusses.

### Prefabricate the Tubes

Tubes are a bit harder to make, because each one must be cut out, then folded four times and cemented together. It may take a few minutes to make each of these members, but do the job carefully—the load-carrying capacity of your bridge depends on it!

#### Here's how to build the tubes:

3) These diagrams show how each of the four different types of tubes should be laid out. The solid lines indicate the outline of the member—you will cut along these lines. The dotted lines indicate where the member will be folded.

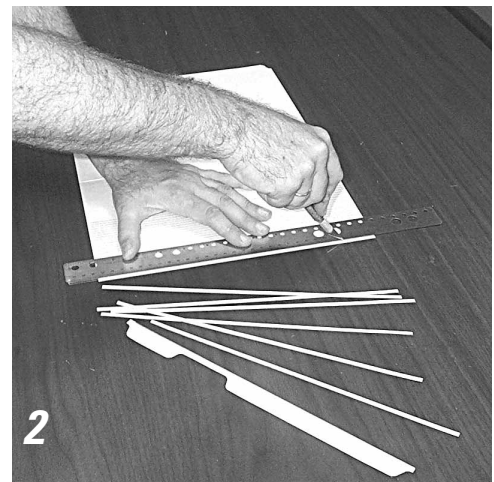
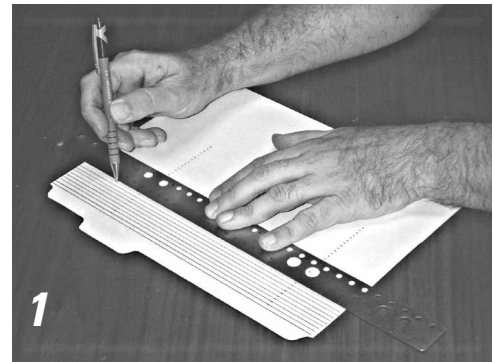

**10 mm x 10 mm Tube (Top Chords & End Posts)**



**10 mm x 6 mm Tube (Verticals)**

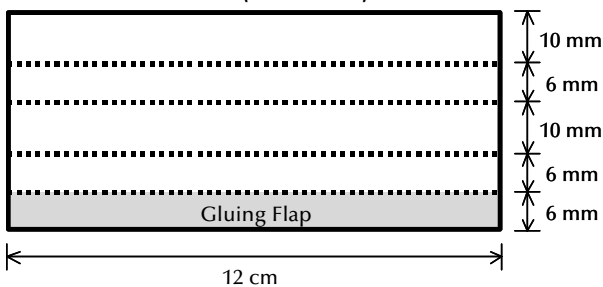

**15 mm x 6 mm Tube (Floor Beams)**



**6 mm x 6 mm Tube (Struts)**

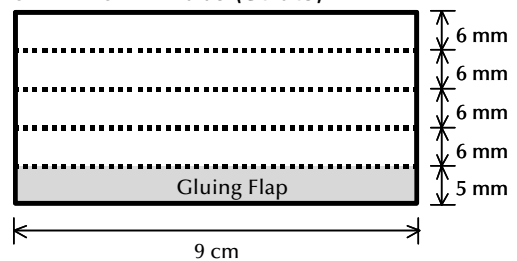

4) Using a ball-point pen and a ruler (or a T-square, as shown in the photo), lay out all the tubes specified in the Schedule of Truss Members. Start by measuring and marking the parallel edges and fold-lines as accurately as possible on the file-folder cardboard. When you draw the fold-lines, *press hard* with the pen. The indentations made by the pen will make the cardboard easier to fold. Now draw perpendicular lines to indicate the lengths of the members, as specified in the Schedule of Truss Members. It is best to mark the lengths a bit oversize now, then trim them to the exact length later, when you build the trusses. In planning your layout, note that you can get two verticals, three struts, or three floor beams from each 30cm length of material.

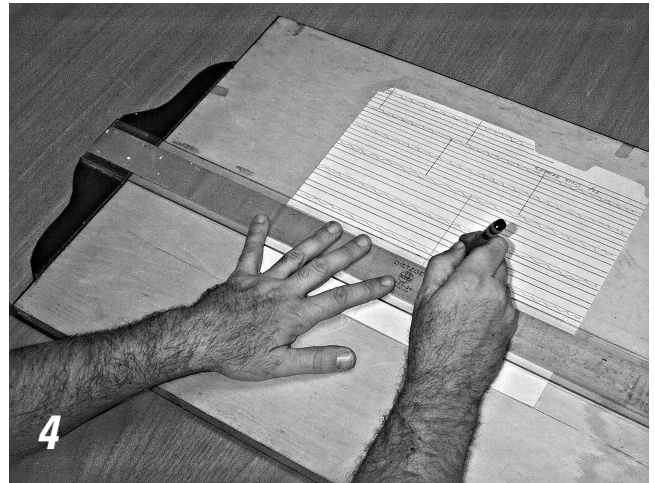

4

5) Once you have drawn all the tubes, cut them out with a scissors or knife. Remember *not* to cut the fold lines.



5

6) When all of the members have been cut out, you are ready to begin folding them into tubes.

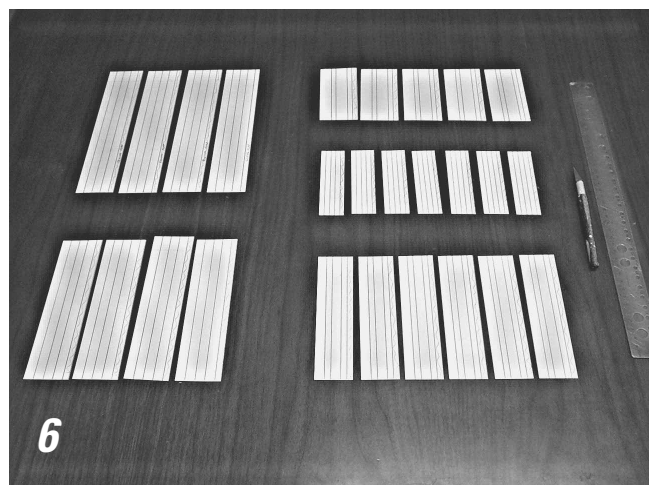

6

7) Starting with one of the 10mm x 10mm members, fold and crease each of the four fold-lines. To help you make the folds straight, lay a ruler along each fold-line as you bend the cardboard.



8) Once you have made all four folds, the member will form a square tube, as shown here.



9) We will use rubber cement to attach the “gluing flap” to the other free edge of the tube. Rubber cement works well for his job, because it dries very quickly and because these joints do not require the greater strength provided by wood glue.

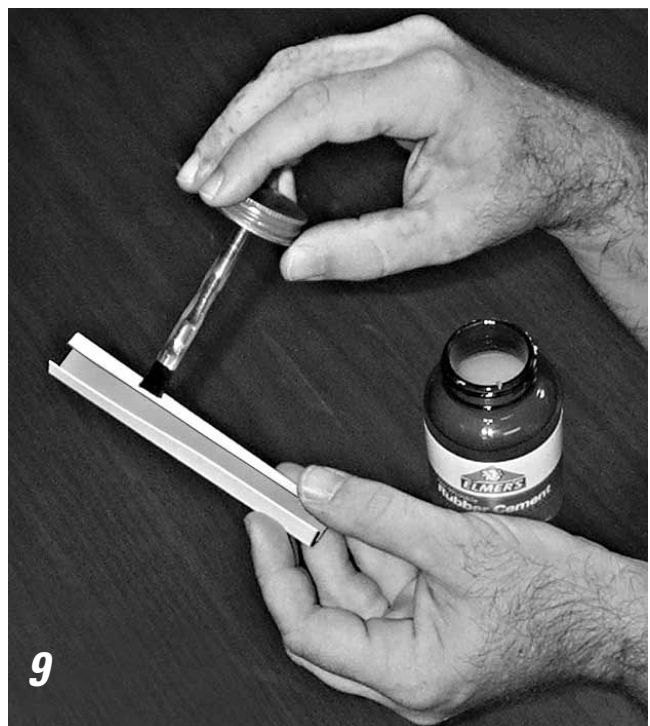

**10)** Apply an even coat of rubber cement to both surfaces that will be bonded together, as shown here. Wait 2-3 minutes, until the cement is tacky. (If the cement is still wet when you put the glued surfaces together, you'll have to hold them together as the cement dries. If the cement is sticky, but not quite dry, the two surfaces will bond together as soon as they touch. To get the timing right, you might want to practice on a scrap piece of cardboard before actually gluing the tubes together.)

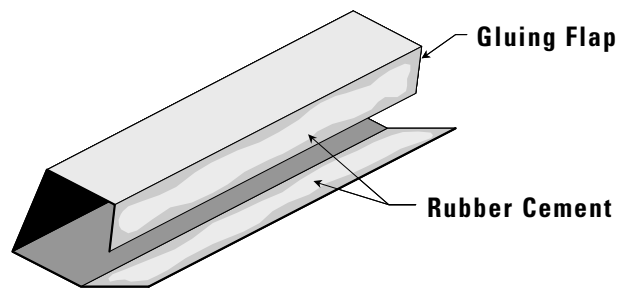

**10**

**11)** Now carefully bring the two cemented surfaces together (**A**) to form a square cross-section (**B**). Note that the gluing flap goes on the *inside* of the completed tube. Immediately flatten the tube on your building board (**C**) and hold it flat for a few seconds, until the cement sets.

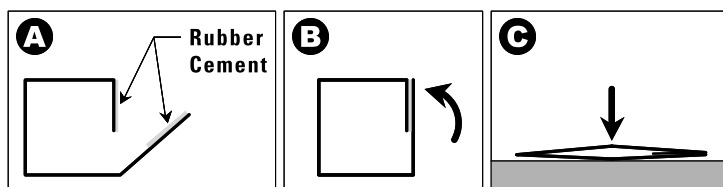

**11**

**12)** Flattening the tube in this manner does two things. First, it ensures that the cemented surfaces are firmly in contact with each other; and second, it ensures that the completed member is not curved or twisted.

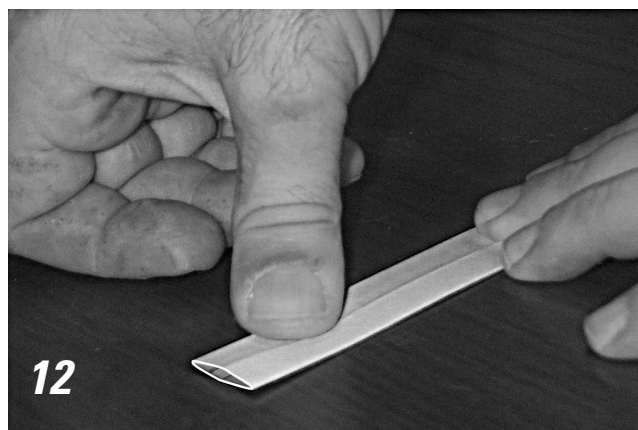

**13)** After the rubber cement has dried, pick up the tube and reshape it back into a square cross-section.

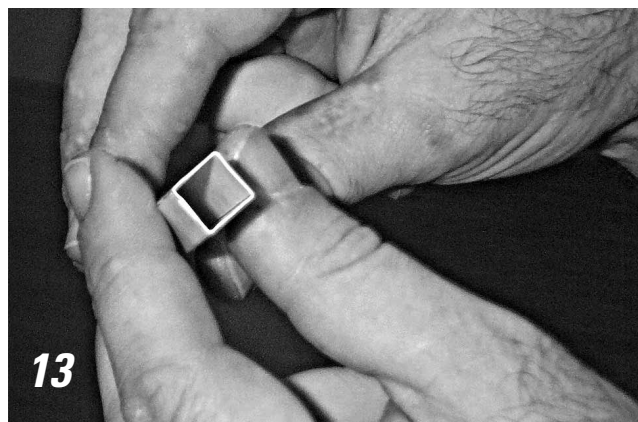

Now repeat Steps 7 through 13 for all of the remaining tube members.

## Prefabricate the Gusset Plates

Our example bridge uses a total of 58 gusset plates to connect the structural members together. If you wanted to make these components in the easiest possible way, you could simply cut out 58 cardboard rectangles, each measuring 40mm x 30mm. These would work fine; however, they would not look authentic, and they would use a lot more cardboard than necessary. The gusset plates shown in Drawing SD-2 more accurately depict real truss connections.

To make the authentic gusset plates, the full-scale layout provided on Drawing SD-2 must be transferred to a file folder. There are three possible ways to accomplish this: (1) you can lay a sheet of carbon paper on the file folder, then lay Drawing SD-2 on top of the carbon paper, and trace over the outline of each gusset plate with a pen or pencil; (2) you can cut out the gusset plates from Drawing SD-2, lay them on the file folder, and trace around each one with a sharp pencil or pen; or (3) if you have access to a copy machine with a “single sheet feeder,” you can photocopy the patterns directly onto file-folder cardboard. You’ll need to cut the folders to 8 ½” x 11” size, so they will run through the single sheet feeder without jamming. Clearly this third option is easiest and most accurate. No matter which method you use, remember that you will need to do the process twice, because Drawing SD-2 only shows half of the required gusset plates.

**14)** Once you have transferred the gusset plate patterns onto the cardboard, carefully cut out each gusset plate with a sharp scissors.

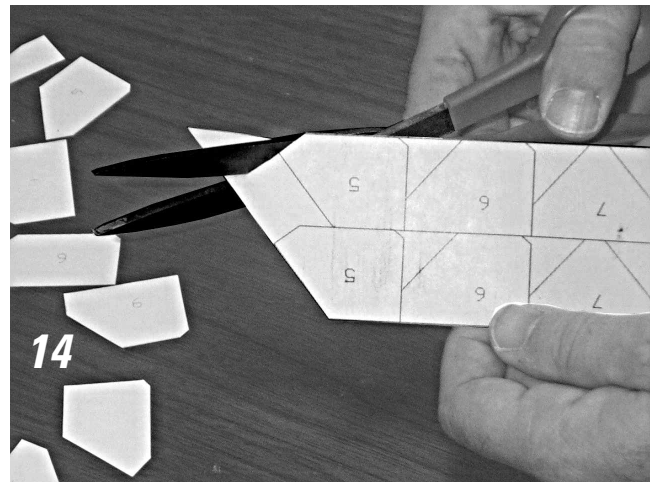

**15)** The prefabrication of structural members is now complete. We’re ready to start building!

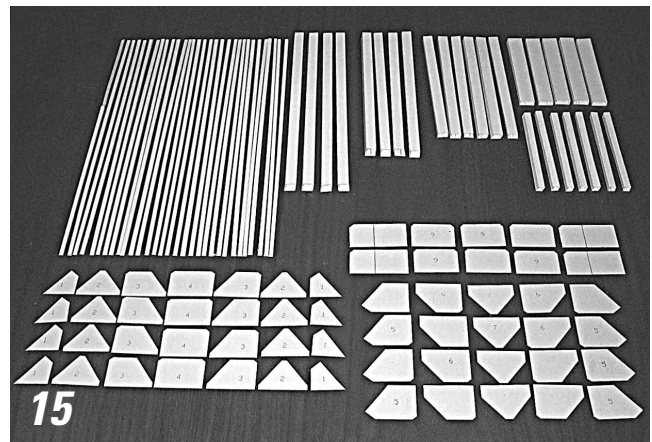



## On an Actual Bridge Project

### Who prefabricates structural components?

On an actual bridge project, steel structural members and connections are made by a **steel fabricator**. The steel fabricator is a member of the Construction Team and is usually a subcontractor. The fabricator's work is done in a shop, not on the construction site, in order to achieve the highest possible quality.

## Set up the Construction Site

**16)** Find a large, flat tabletop to use as your construction site. Place your building board on the tabletop. Place Drawing SD-1 on top of the board, and put a layer of wax paper over it. Use a few pins or staples to keep everything in place.

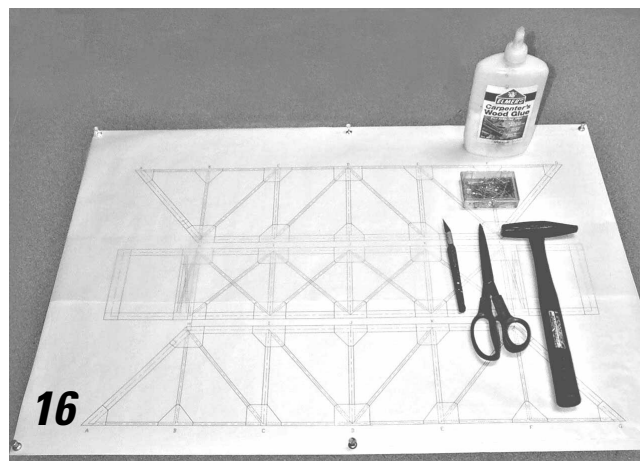

## On an Actual Bridge Project

### How does the Constructor set up the construction site?

The setup of a construction site varies from project to project. However, on just about any major project site, the Constructor will provide the following:

- A construction office with telephones, computers, storage for important documents, and workspace for the Superintendent—the on-site construction supervisor.
- Space for on-site storage of construction materials.
- Access to the site for construction vehicles.
- A location for the crane that will be used to lift pieces of the structure into place.
- Traffic control and safety fencing to keep unauthorized vehicles and pedestrians away from the site.
- Electrical power for tools and equipment.

# Build the Structure

## Build the Main Trusses

**17)** Start by placing the appropriate gusset plates directly onto the drawings of the two main trusses, at the locations designated in the Schedule of Gusset Plates. Hold each gusset plate in place with two pins. (If you use only one pin, the plate will be able to rotate out of position.) Put each pin through a point on the gusset plate where no members will be attached; otherwise, the pins will be in the way when you glue the members to the gusset plates.

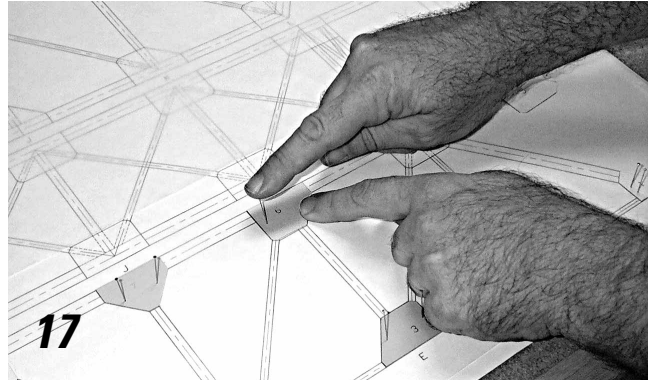

**18)** When you're done, you will have 24 gusset plates pinned to the board.

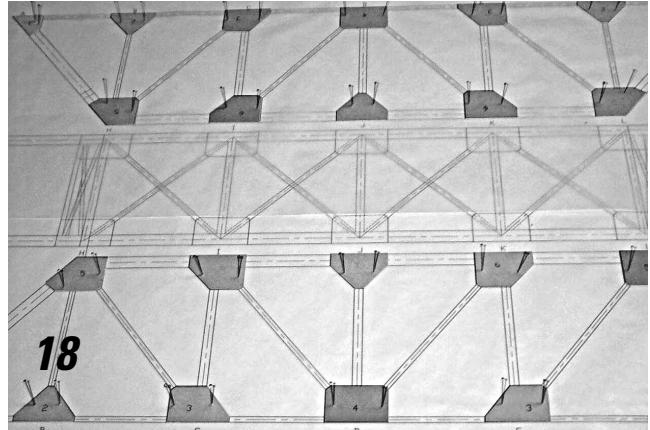

**19)** Now add the 4mm bars. Select one of the cardboard strips you prefabricated in Step 2. Place it in the correct position, and mark its length with a pencil or pen. (The photo shows Member DJ, a diagonal, being marked. Note that the bottom chord members are already in place.)

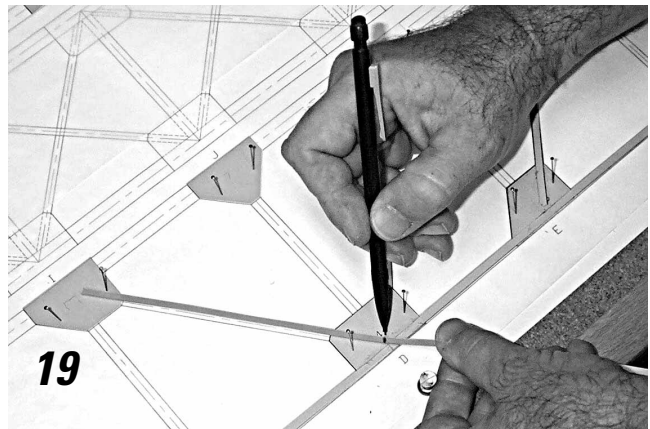

**20)** Spread wood glue on the two gusset plates to which the member will be attached. You can apply the glue directly from the bottle; however, you will find that you can do a neater job if you use a scrap piece of cardboard or wood as an applicator, as shown here. Do not use rubber cement for these joints! It's not strong enough.

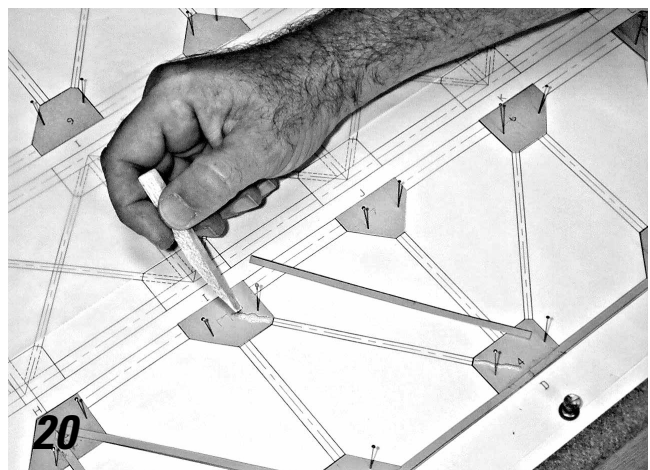

21) Now place the 4mm strip onto the gusset plates, using the drawing beneath to ensure that it is in the correct position.

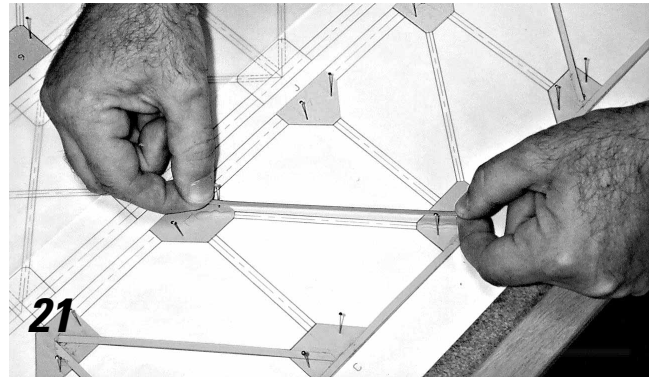

22) Press firmly on both ends of the member, and hold it in place for about 30 seconds, until the glue starts to set. Be careful not to glue your fingers to the gusset plates!

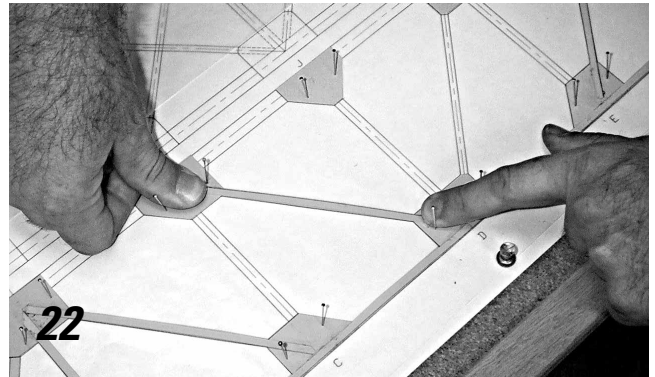

23) Repeat Steps 19 through 22 for each of the 16 bars on the two trusses. Note that the two outermost verticals on each truss are bars. The remaining three verticals are tubes, which will be attached in the next series of steps.

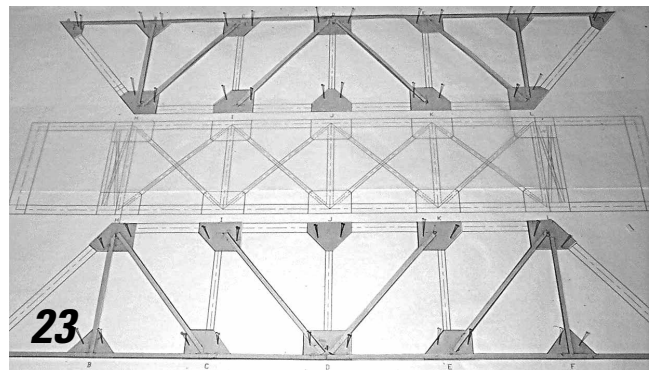

### On an Actual Bridge Project

#### How are members attached to gusset plates?

On modern bridges, structural members are either bolted or welded to the gusset plates. When two pieces of steel are welded, they are actually fused together to make a single piece of steel. Welds are strong and relatively inexpensive, but they require highly skilled workers and specialized equipment to make. Thus welded connections are often used for portions of a structure that can be assembled in the shop by the steel fabricator. Bolted connections do not require specialized equipment and are relatively easy to assemble; thus, they are often used for field connections—those that are assembled on the construction site, rather than in the fabrication shop.

24) Now you will attach the tubes to the gusset plates, but only on one of the two trusses—the one closer to you. Start by placing one of the 10mm x 10mm tubes into position on the top chord and marking its length with a pencil or pen. (Member IK is shown in the photo.)

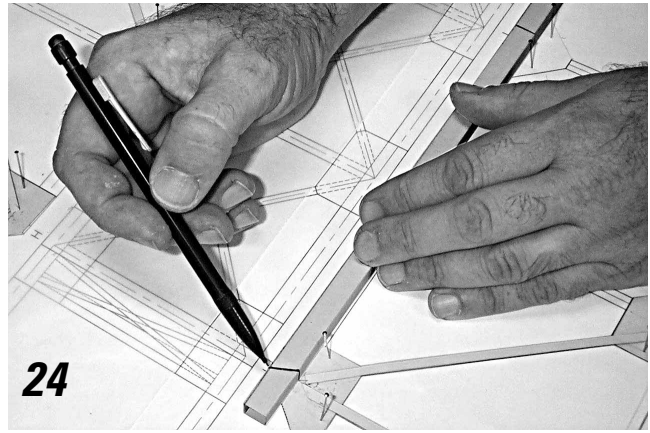

25) Cut this member to the correct length. Some of the tubes—like this one—must be cut at an angle. You'll need to use your knife or razor blade to make these cuts.

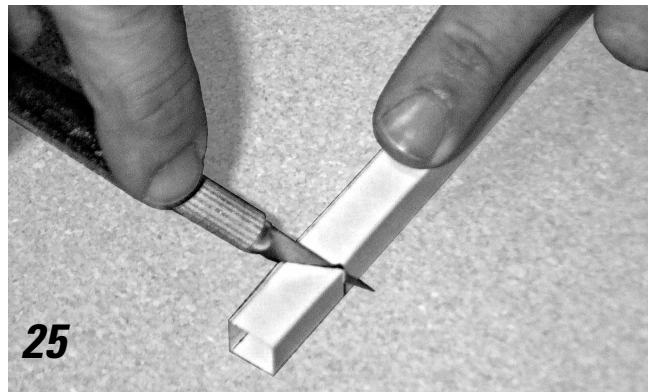

26) Other members must be cut square. For these cuts, it is easier to flatten the end of the tube, and use a scissors.

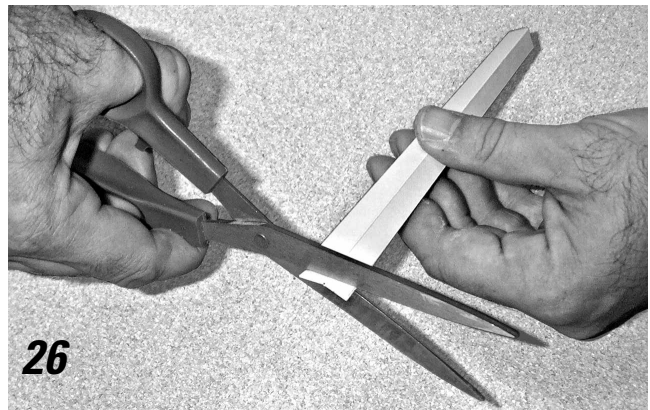

27) Now apply glue to the two gusset plates.

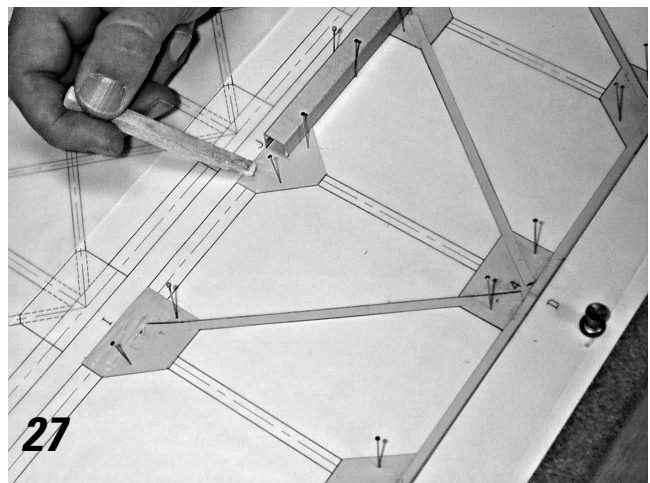

28) Put the member into position.

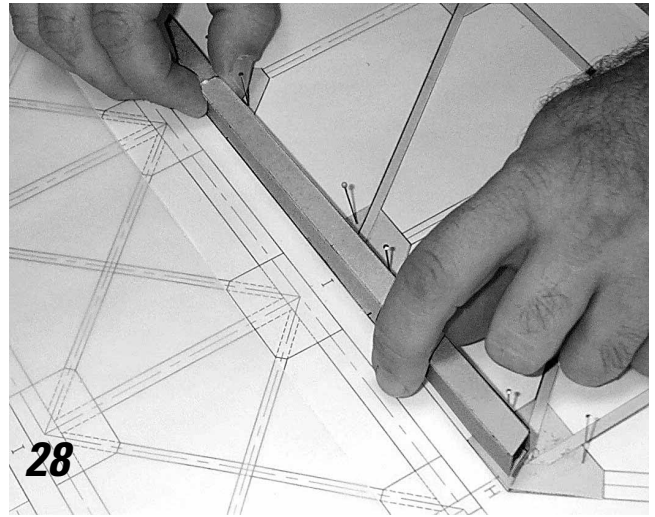

29) And hold the member in place until the glue sets.

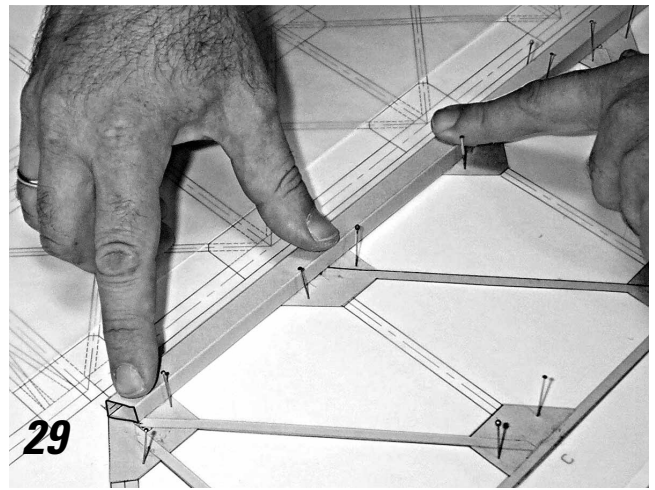

30) As you assemble the main trusses, it is very important to keep the cross-section of each tube as close to square as possible. Do this by pushing a pin into the building board on either side of each tube, as shown. The pins will keep the sides of the tube vertical as you assemble the remainder of the truss.

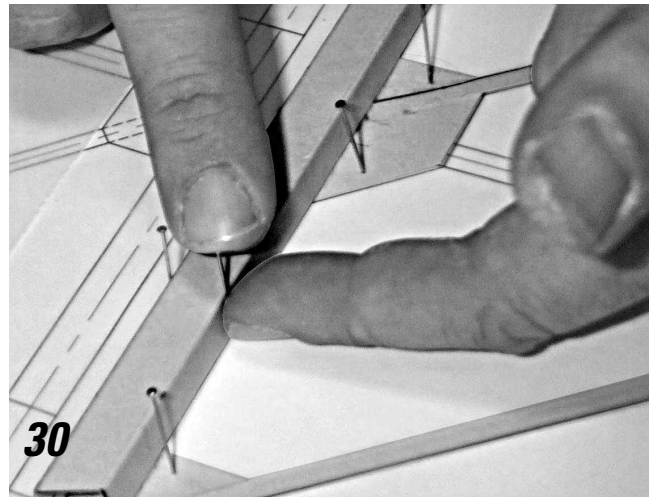

**31)** Repeat Steps 24 through 30 for the remaining tubes. Be sure to use the correct sizes—10mm x 10mm tubes for the top chords and end posts, and 10mm x 6mm tubes for the three interior verticals. The photo shows the vertical member DK being glued into position. Note that the verticals should be placed with their shorter (6mm) side flat on the building board and the longer (10mm) side standing upright.

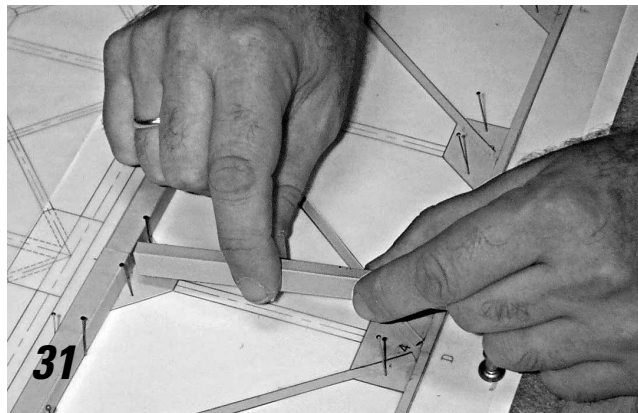

**32)** When all of the tubes are glued in place, the result should look like this. Note again that the tubes are only glued to one of the two trusses on the building board.

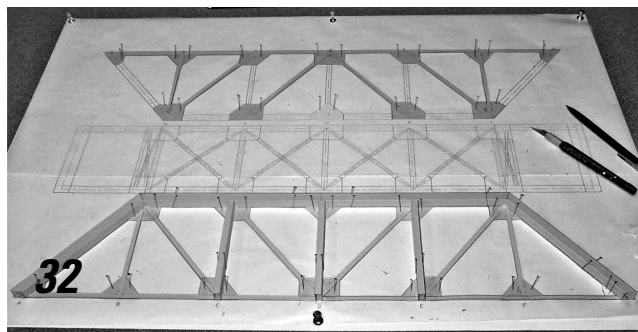

**33)** The two subassemblies currently on the board are actually two halves of the *same* truss. Now we will put them together. Begin with the “upper half” — the one composed only of gusset plates and bars. Remove all of the pins holding the upper half to the building board, and lift it free. *Carefully* separate this subassembly from the wax paper. If you tear one of these members, your bridge will probably not be able to carry its specified 5 kilogram load. Once you have separated the subassembly from the wax paper, put it aside.

On the “lower half” — the one closest to you—pull out all of the pins in the gusset plates, but do not remove the pins you added in Step 30.

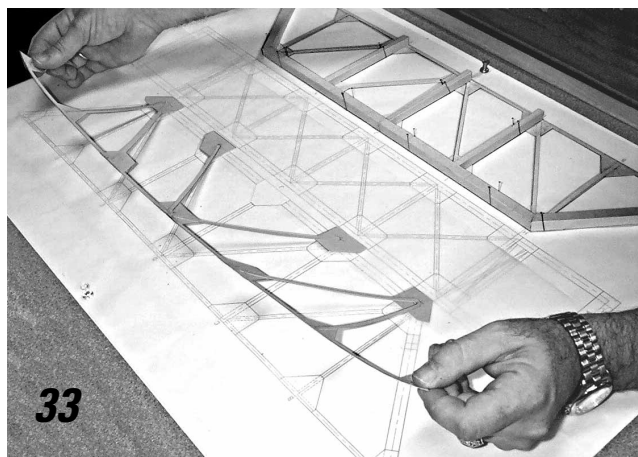

**34)** Put glue at the appropriate locations on the lower half of the truss—the places where the upper gusset plates will connect to the tubes on the lower half.

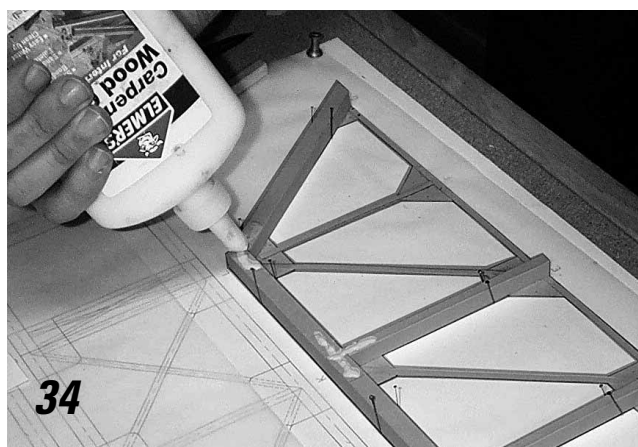

35) Carefully place the upper half directly on top of the lower half. Ensure that the two halves are aligned before the glue starts to set.



36) Note that, when you assemble the two halves, you are creating the *doubled bars* specified in the Schedule of Truss Members. It is very important that both of the bars in each pair are stretched tightly between gusset plates. If one is tight and the other is loose, the two will not share load equally and may fail prematurely. Use your thumbs to pull the upper bars tight, as shown.

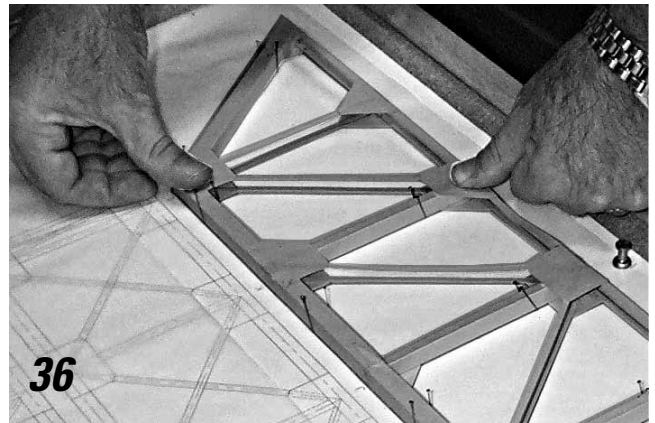

37) At this point, the assembled truss is missing only the upper gusset plate at Connection K. This one was left behind on the building board, because it is not attached to any bars on the upper half of the truss. Glue this final gusset plate in place.

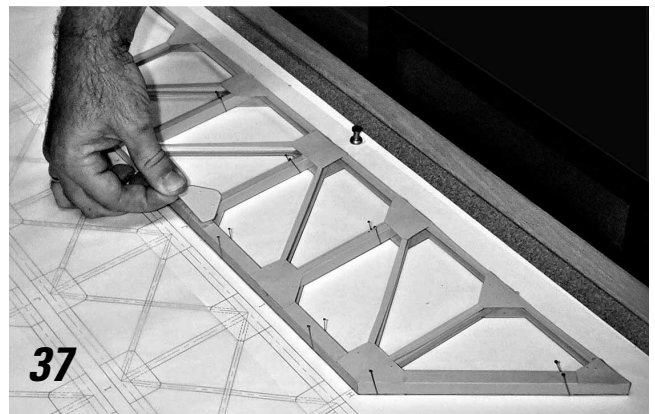

Now remove the truss from the board, and set it aside. Using exactly the same procedure (Steps 17 through 37) build a second *identical* main truss.

### Build the Lateral Bracing Subassembly

38) Following the same procedure you used for the main trusses, assemble the lateral bracing subassembly, which will connect the two main trusses together. Start by pinning the gusset plates to the board; then add the lateral bracing, made of *single* 4mm bars. Finally add the struts, which are made of 6mm x 6mm tubes, all exactly 9 cm long.

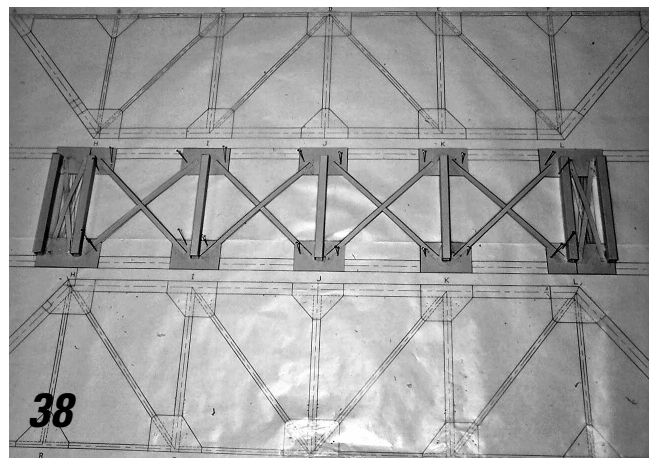

39) When the lateral bracing subassembly is complete, remove it from the building board. The three major subassemblies are now done. We are ready to assemble the three-dimensional structure.

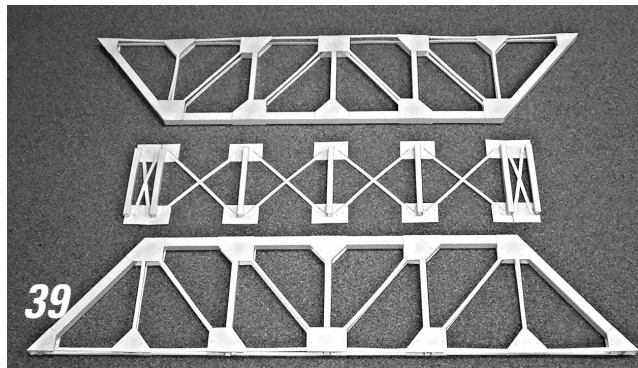

### Connect the Two Trusses Together

40) Place the lateral bracing subassembly flat on the building board. Apply glue to all five gusset plates on one side.

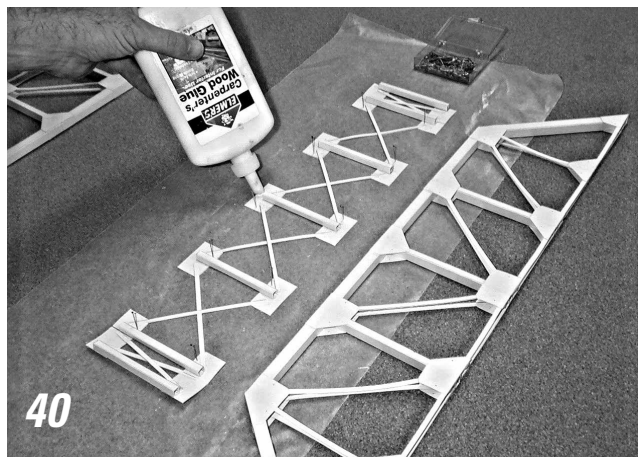

41) Position one of the two main trusses. (Note that you are assembling the bridge upside down.) Once the truss is in position, check to ensure that it is vertical, and hold it in place for a minute or so.

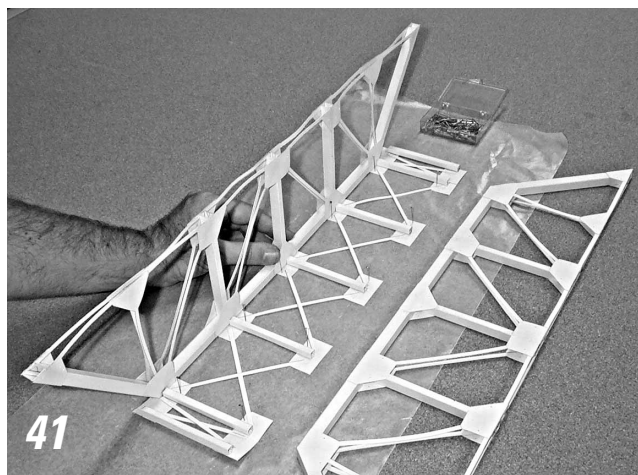

42) Now add the second truss in the same manner.

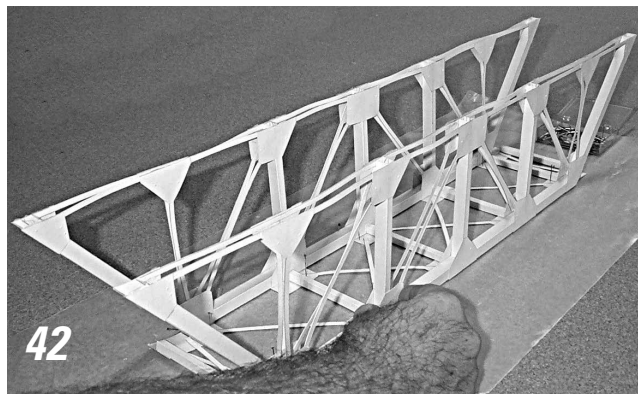



43) You may find it helpful to use pins on the outside of the two trusses to hold the subassemblies together while the glue sets. Do not remove any pins or move the bridge until the glue has dried completely.



Q3

What are the purposes of the struts and lateral bracing?

As you can see from Steps 40 – 42, the struts and lateral bracing help connect the two main trusses together. What other purposes do you think these members serve?

**Add Floor Beams**

Just as the struts connect the two trusses together at their top chords, the floor beams connect the trusses together at their bottom chords. As you might have noticed when you prefabricated these members, the floor beams are one centimeter longer than the struts. Why? Since there are no gusset plates to connect the floor beams to the bottom chord, we will use the outer 5mm on each end of the floor beams to form *connecting angles*. These angles will connect the floor beams to the gusset plates on the inside of each truss.

44) Draw two lines completely around the tube, as shown on this diagram. (An easy way to do this is to flatten the tube, then use a ruler to draw the lines.) The two lines should be *exactly* 9cm apart.

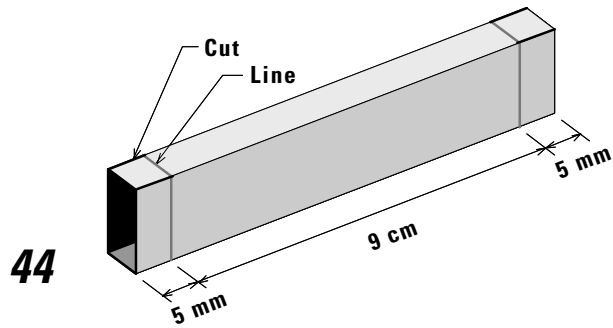

45) Now use your knife to slice through all four corners of the beam, as shown in the photo. Cut *only* as far as the line you drew in Step 44.



**46)** At each end of the beam, fold all four sides outward along the line. These four flaps form the connecting angles that we will use to attach the beam to the bottom chord.

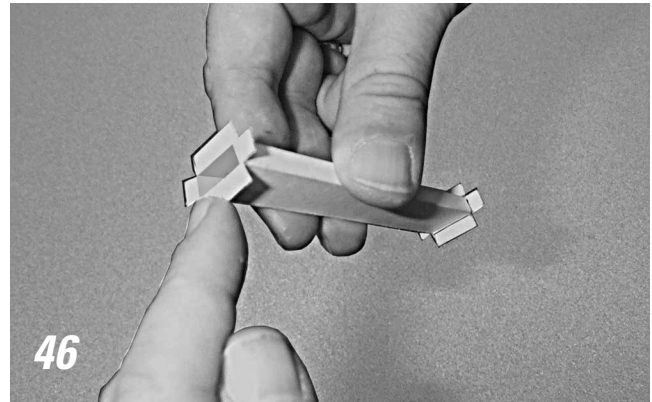

**47)** Apply glue to all four flaps.

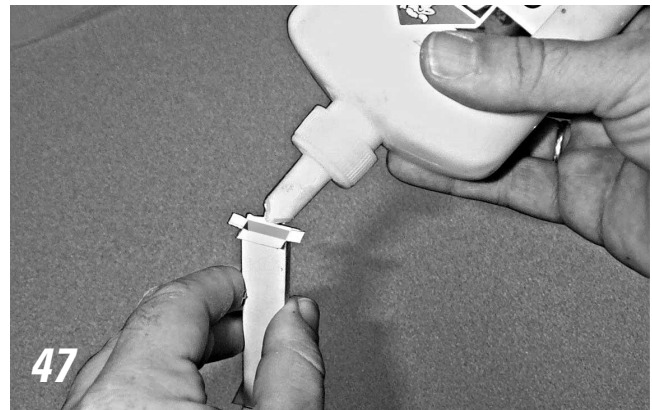

**48)** Place the beam between Connections D and D', at the center of the bottom chords. Note the orientation of the beam—the larger dimension is vertical.

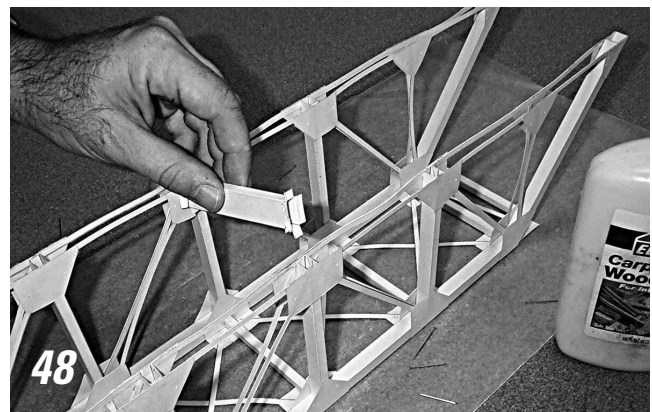

**49)** Press inward on the two gusset plates until the glue sets.

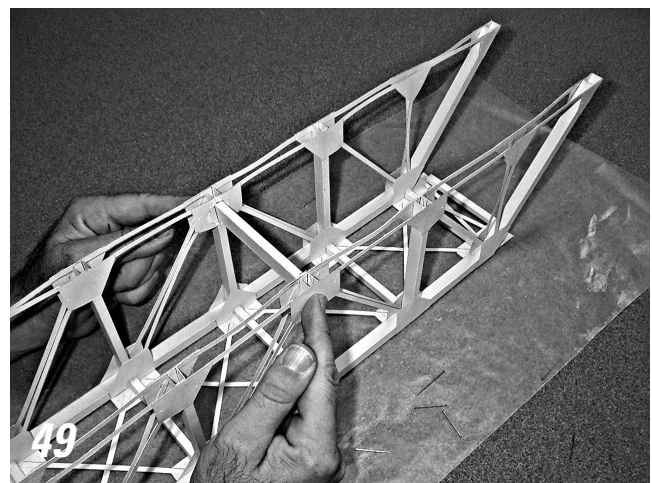

50) Now repeat the process for floor beams CC' and EE'.

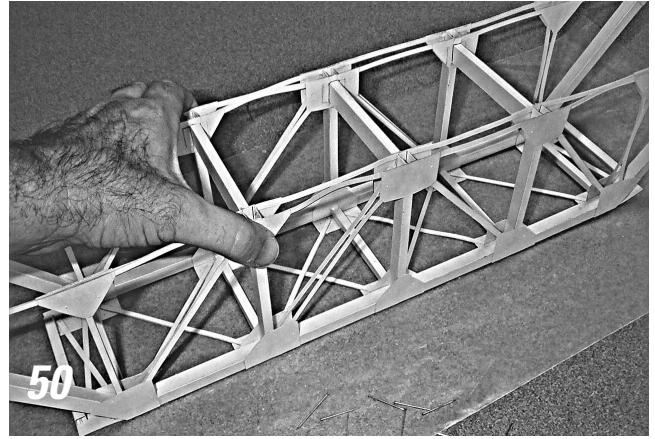

51) Cut out two rectangles of file-folder cardboard with these dimensions, and fold each one sharply along the dotted line. These are the two end floor beams AA' and GG'.

28 mm x 13 mm L-angle (Floor Beams)

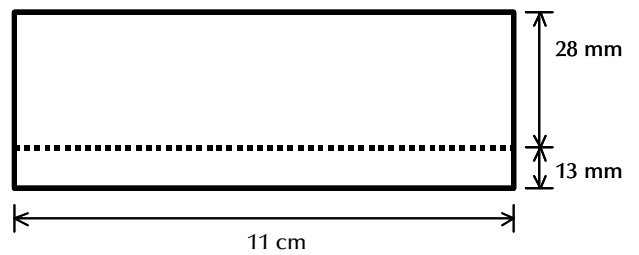

51

52) Glue the end floor beams in place, as shown here.

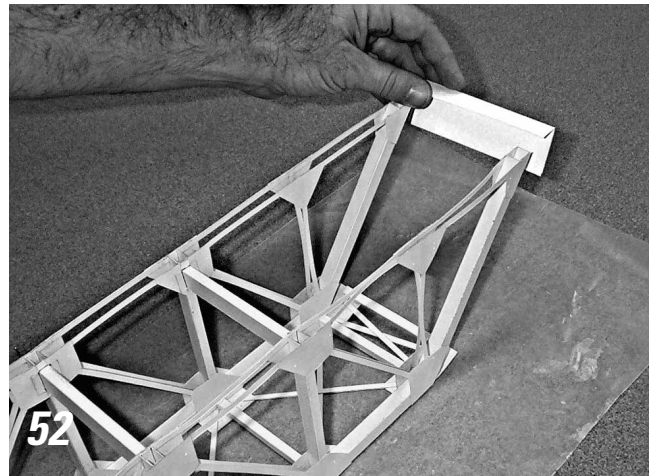

53) Glue the two remaining floor beams (BB' and FF') in place. Because there is no tube between the pairs of gusset plates at Connections B, B', F, and F', you may find it helpful to clamp the beam in place with four clothespins, as shown.

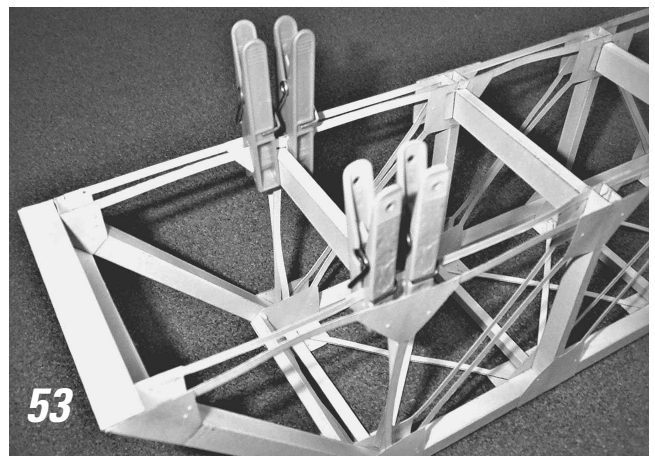

## On an Actual Bridge Project

### How are the floor beams attached to the main trusses?

In the Gallery of Truss Bridges (Appendix A), the photos of Bridges 9 and 12 show a typical arrangement used to attach the floor beams to the main trusses in older pin-connected bridges. In both of these bridges, the floor beam is suspended from the pin by two U-shaped bolts. Modern trusses generally use connecting angels very similar to the ones we used in our model.

## Add the Portal Bracing

You have already created the portal bracing. You did it when you made the lateral bracing subassembly in Step 38. Now all you need to do is glue it into place.

54) Apply glue to the top front of the two end posts.

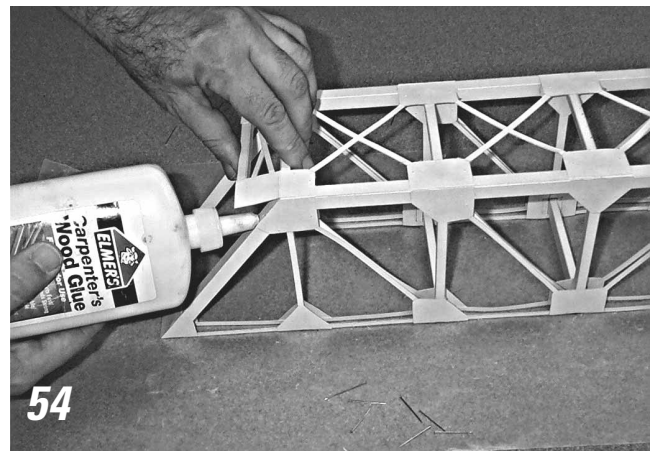

55) Fold the portal bracing down onto the end posts and hold in place until the glue sets. Do the same for the portal bracing on the opposite end of the bridge.

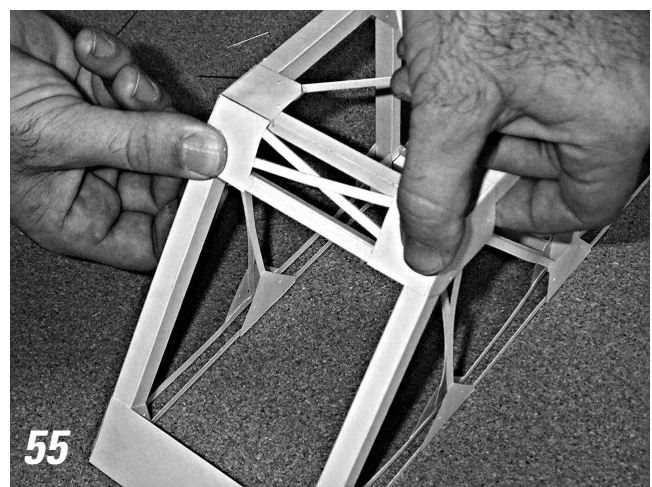

Q

4

What is the purpose of the portal bracing?

The portal bracing serves an important purpose in a through truss bridge. What do you think that purpose is? To answer this question, look at your own model bridge, and try to visualize how it might fail if the portal bracing were not present.

**Perform a Quality Control Inspection**

56) The bridge is finished! But before you place it into service, you should carefully inspect the structure to ensure that it has been built according to the plans and specifications. Are all the structural members positioned correctly? Are any of them cut, torn, or dented? If so, repair or reinforce these points before you load the structure. Are all of the members firmly attached to their gusset plates? If not, add more glue to these joints. It is important that the connections are stronger than the members themselves.

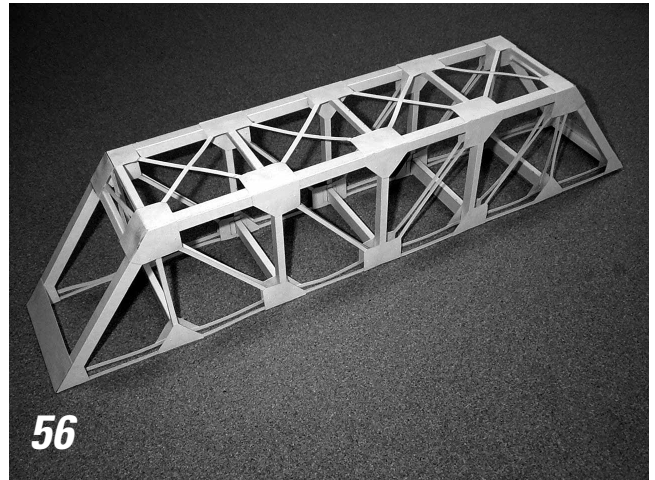

Q

5

Why are truss bridges less common today?

Trusses are used much less commonly in bridge structures today than they were a hundred years ago. Based on your own experience with the Grant Road Bridge project, why do you think truss bridges are less common today?

## Place the Bridge Into Service

If this were a real bridge, we would be ready to hold a ribbon-cutting ceremony and open the bridge to traffic. For our model bridge, we'll simulate the grand opening by applying the prescribed 5-kilogram load to the structure. We will use a stack of books as the load.

57) To prepare for the load test, set up two books as abutments approximately 59 cm apart, and put the bridge on top of them. Place a coin on top of each gusset plate at Connections J, J', K, K', L, and L'. Trusses are designed to be loaded *only* at the joints; the coins will ensure that the weight of the books is transmitted to the main trusses only at these locations.

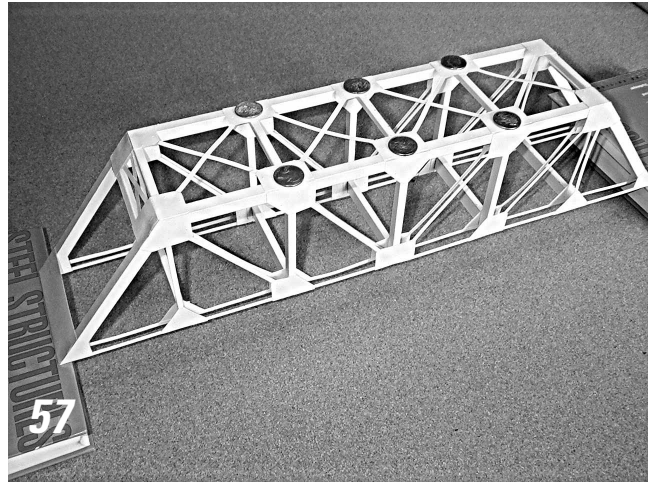

58) Using a metric scale, experiment with various books until you have assembled a stack with a mass of approximately 5 kilograms.

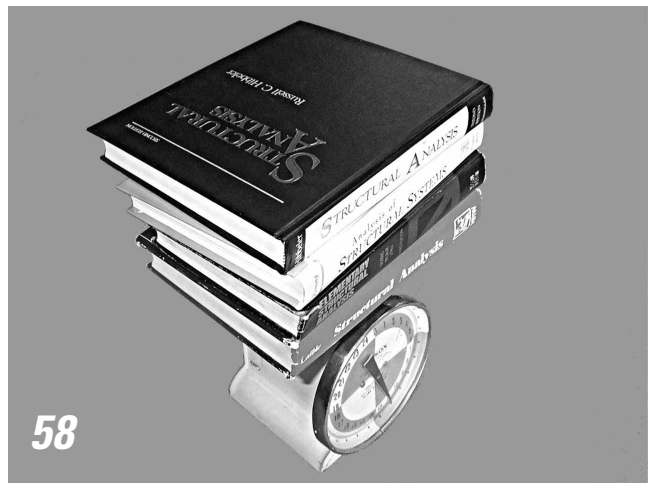

59) Now place the books gently, one at a time onto the top of the truss. Keep them centered. Leave the full 5-kilogram stack of books is in place for a few minutes.

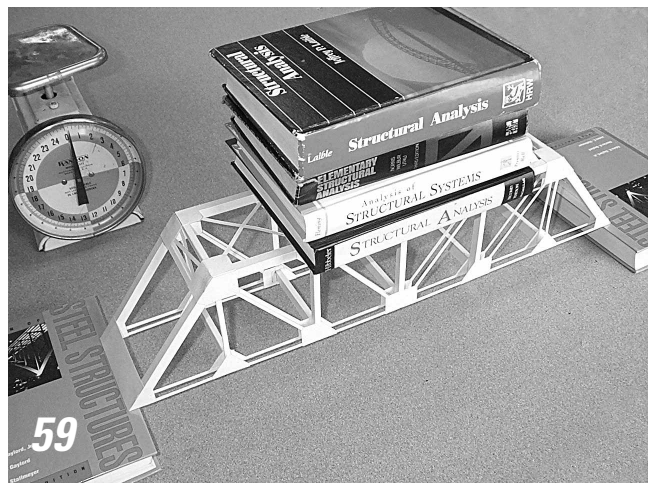

**60)** Another way to load-test the bridge is to suspend a bucket filled with sand from the floor beams. The total mass of the bucket, sand, and loading platform should be 5 kilograms.

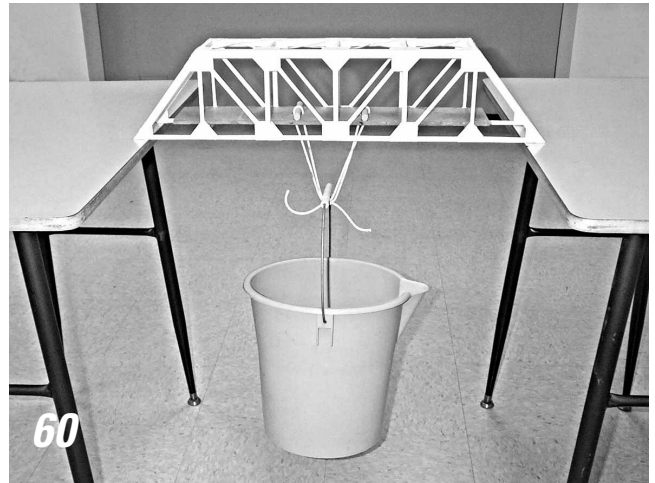

**61)** You'll need to build a wooden platform like this one to support the bucket. The platform is 8 cm wide and 50 cm long. It has two 1.5 cm holes drilled 10 cm apart in the center. The bucket hangs from a single loop of heavy cord. The two ends of the loop are pushed through the holes in the platform and held in place with two pencils or wooden dowels. The platform rests on all five interior floor beams of the bridge. Don't just hang the bucket from floor beam DD'; the concentrated weight will probably rip the floor beam out of the structure.

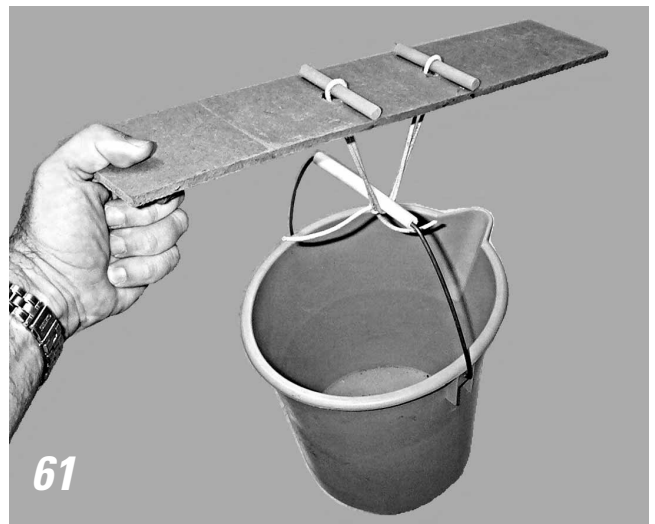

**Q6**

**Which method of loading is better?**

Compare the two methods of loading described in Steps 59 and 60. What are the advantages of each method?

If your bridge carries the prescribed 5-kilogram loading, congratulations! Your bridge construction project is a success! Weigh the bridge. You'll find that it has a mass of about 55 grams—a strength-to-weight ratio of over 90. That's not bad for a structure made of paper.

If you built your bridge well, it should actually be able to carry about 10 kilograms before it collapses. But resist the temptation to load it to failure! Engineers take great pride in the physical products of their work, and you should too. You've put a lot of time and effort into this project. Save your bridge; don't destroy it. And remember that engineers *always* design structures to stand up, not to collapse!



### Why is the bridge “too strong?”

**The functional requirements for the Grant Road Bridge specify that the structure must be capable of carrying a 5 kilogram mass. The actual capacity of the structure is about 10 kilograms. Why did the structural engineer design the bridge with so much extra capacity?**

While your bridge still has the load in place, take a moment to examine how the structure is carrying the load. You can learn a lot about structural engineering just by carefully observing how the members in this bridge behave when a load is applied. Note that some members are stretched tightly in tension. Some are slack—they appear to have no internal force at all. Others are in compression, though these are a bit harder to identify.



### How does your model bridge carry load?

**Which members of the Grant Road Bridge are in tension? Which are in compression?**



### Why tubes and bars?

**Why did the structural engineer specify tubes for some members and bars for others?**



### How does construction quality affect structural performance?

**Based on your own experience on this project, explain how the quality of the Constructor’s work affects the performance of a structure. If you make errors in construction, or if your glue joints are not strong enough, or if parts of the structure are damaged during assembly, how are the function and appearance of the structure affected?**

## **Conclusion**

The bridge construction project is complete. In doing the project, you had the opportunity to learn a lot about bridges, about construction, and about some basic principles of structural engineering. You also practiced some techniques for working with a rather unusual construction material. Perhaps you had some fun too. But you haven’t actually *done* any engineering yet. Stay tuned for Learning Activity #2, where we will design and conduct a series of experiments to determine the strengths of structural members—the first step in the process of designing your own bridge.



## Answers to the Questions

1) **Can you identify the component parts of a truss bridge?** The component parts of a typical Pratt through truss bridge are annotated on the photo below.



2) **Can you identify the configuration of a truss bridge?** The configurations of the bridges pictured in the Gallery of Truss Bridges (Appendix A) are as follows:

#	Truss Configuration	Through, Deck, or Pony
1	Warren with Verticals	Through
2	Baltimore	Through
3	Pratt	Pony
4	Waddell "A" Truss	Through
5	Fink	Through
6	Pratt	Through
7	Pratt	Deck
8	Camelback	Through
9	Double Intersection Pratt	Through
10	Pennsylvania	Through
11	Non-standard "A" Truss	Through
12	Pratt	Through
13	Lattice	Through
14	Warren with Verticals (background)	Deck
15	Parker	Through

#	Truss Configuration	Through, Deck, or Pony
16	Baltimore (left) & Pratt (right)	Through
17	Pratt	Through
18	Double Intersection Warren	Deck
19	Parker	Through
20	Pennsylvania	Through
21	Parker	Pony
22	Bowstring	Through
23	Warren with Verticals	Pony
24	Warren with Verticals	Through
25	Bowstring	Pony
26	Pratt	Deck
27	Warren with Verticals	Pony
28	Parker	Through
29	Pratt Arch	Deck
30	Pratt Arch	Deck

3) **What are the purposes of the struts and lateral bracing?** If you look at the Grant Road Bridge from directly above (plan view), you notice that the two top chords, the struts, and the lateral bracing form a truss, as shown in **A** below:

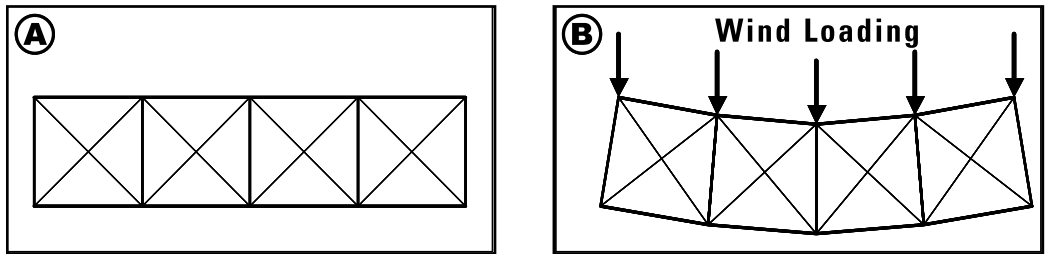

This truss lies in a horizontal plane, rather than standing vertically, as the two main trusses do; but it is a truss nonetheless. And if you view this subassembly as a truss, you'll probably be able to see one of its major purposes—carrying loads caused by wind striking the bridge from the side, as shown in **B**. The struts and lateral bracing also prevent the top chords from buckling sideways, as a result of compression in those members. We'll learn more about buckling in Learning Activity #2.

4) **What is the purpose of the portal bracing?** Portal bracing keeps the two main trusses from tipping over sideways when the bridge is loaded. Diagram **A** below shows a front view of the Grant Road Bridge. If the portal bracing were not present, wind striking the structure from the side would easily knock it over, as shown in **B**. The portal bracing adds rigidity to the structure by ensuring that the tops of the end posts remain vertical, as in **C**. Like the top lateral bracing, the portal bracing is really just another truss, which uses members arranged in interconnected triangles to add rigidity to the structure.

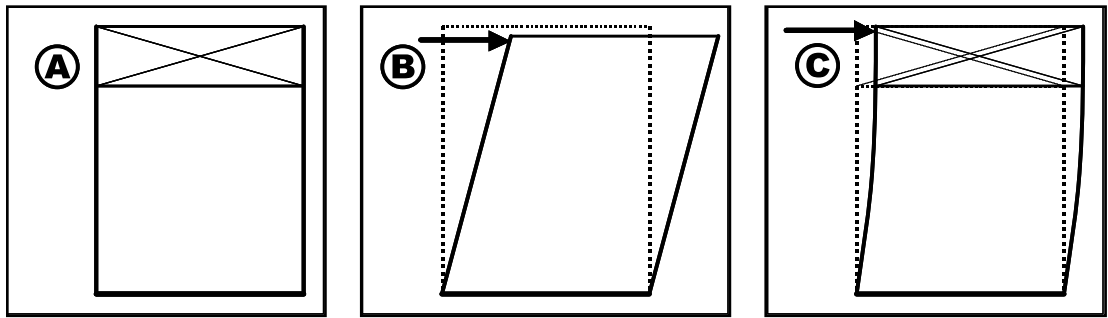

In actual bridges, the portal bracing takes many different forms, as you can readily see in the Gallery of Truss Bridges (Appendix A). In older bridges, this portion of the structure was often decorated with ornate ironwork, as in Bridges 6, 8, and 12 in the Gallery.

5) **Why are truss bridges less common today?** Today most short-span and medium-span bridges use the **beam** as their principal structural element. Yet, in comparison with the beam, the truss is a far more efficient structure. For a given span and loading, a well-designed truss uses far less material than a beam. So why are beams used more often in modern bridge construction? To answer this question, you must recognize that the material cost is only a portion of the total cost of building a bridge. The costs of fabricating structural elements

and the cost of actually building the structure also contribute significantly to the total cost. As you probably now recognize from your experience in this project, truss bridges are relatively complex structures. A truss has many more members and connecting elements and thus requires considerably greater effort to fabricate and assemble than a beam. In the 19<sup>th</sup> century, when skilled labor was relatively cheap, and construction materials were relatively expensive, truss bridges could generally be built for the lower total cost. But in recent times, the cost of skilled labor has increased in comparison with the cost of materials. Fabrication and construction costs have become at least as important as material cost in bridge construction. As a result, beam bridges now can generally be built at a lower total cost than truss bridges.

**6) Which method of loading is better?** Of the two possible methods of loading your bridge, hanging the load from the floor beams is more realistic. On an actual truss bridge, traffic loads are applied to the deck, which is supported by the floor beams. Thus most of the load is transmitted to the main trusses via the floor beams. Loading the bridge by stacking books on top of it is considerably less realistic, but it is much easier to do. If we were to compare the internal member forces developed by these two different types of loading, we would find surprisingly little difference between the two. We'll see this comparison in Learning Activity #3.

**7) Why is the bridge "too strong?"** The structural engineer who designed the Grant Road Bridge didn't know if you would put *exactly* five kilograms of books on the bridge. She wanted to ensure that the bridge would not collapse if you used a slightly larger load. She also didn't know if you would be using the same type of file folders she used as the basis for her design. File folders made by a different manufacturer might be considerably weaker. The engineer knew that a relatively inexperienced Constructor would build the bridge, so she assumed that some minor errors in fabrication or construction might reduce the strength of the bridge somewhat. Because of all this uncertainty, she designed the structure to carry twice as much load as the design requirements specify. This margin of error is called a *factor of safety*. The factor of safety for this structure is approximately 2.

We will work extensively with the factor of safety in Learning Activities #3 and #5.

**8) How does you model bridge carry load?** With the load in place at mid-span, the bottom chords and the diagonals are all in tension. The hip verticals are in tension only if load is applied to the floor beams BB' and FF'. When there is no load on these members, the internal force in the hip verticals is essentially zero. The top chords, the end posts, and all of the other verticals are in compression. We will calculate the actual magnitudes of these tension and compression forces in Learning Activity #3.

**9) Why tubes and bars?** Hollow tubes are much more efficient in carrying compression than are solid bars, because tubes resist buckling more efficiently. (We'll learn more about buckling in Learning Activity #2.) So the engineer has specified tubes for all members that carry compression. For members that carry tension, tubes and bars are equally effective. But, as you know from this project, tubes are quite a bit harder to make than bars. If you were a steel fabricator, you would charge more money to make them. Thus the engineer has specified the less expensive bars for all members that carry tension.

A quick review of the Gallery of Truss Bridges (Appendix A) indicates that many designers of actual truss bridges have made the same design decision—many of these structures use tubes for compression members and bars for tension members.

To see why members of a truss must be specially designed to carry tension and compression, try turning the bridge upside down, and supporting it by its ends. In this configuration, if you apply just a slight downward load at mid-span, the bars will buckle almost immediately. Turning a truss upside down reduces its load-carrying capacity to nearly zero, because members designed for tension are now subjected to compression.

**10) How does construction quality affect structural performance?** Any construction error and any instance of poor workmanship might adversely affect the ability of a structure to carry load. Suppose one of your bottom chord members is 3 mm wide, rather than the 4 mm width required by the plans and specifications. As a result of this “small” fabrication error, the undersized member would be 25% weaker than the designer intended and might fail when the structure is loaded. Suppose you didn’t put enough glue on one of your gusset plate connections. If the glue joint is weaker than the member it is connected to, then the full strength of the member can never be achieved, and a premature connection failure could cause the structure to collapse. Construction quality can mean the difference between a successful structure and a catastrophic failure.

Poor workmanship can also adversely affect the appearance of a completed structure. Sloppy glue joints and unevenly cut gusset plates don’t look good and will probably cause the Owner to be dissatisfied with the finished product, even if it is structurally safe.

## Some Ideas for Enhancing this Learning Activity

Given that actual bridges are always built by teams of construction specialists, it would be appropriate to organize students into teams to do this project. The authenticity of the experience would be further enhanced by assigning students specific roles within each team. One student might be the *project manager*, with overall responsibility for supervising the activity and conducting quality control inspections. One or two might be designated as *steel fabricators*, with responsibility to cut out all members and gusset plates. One might be assigned as the *steel erector*, responsible for trimming each member to size and positioning it on the building board. One might be the *welder*, with responsibility for making all glue joints. The teacher should act in the role of the *Owner*, by assigning the project, accepting the completed structure, placing it into service (by applying the 5 kilogram load), and paying the Constructor (by assigning a grade). At the conclusion of the project, students might be asked to write a reflective essay on what they learned or on how the various team members contributed to the final product.

On actual projects, the Constructor is often selected by a competitive bidding process. To simulate this process, student teams could be asked to begin the project by submitting bids. Each team could be asked to prepare a bid for the least possible number of file folders required to build the bridge. The team that submits the lowest bid (the smallest number of file folders) would win the contract—and perhaps a bonus grade for the project. The team would only earn their bonus, however, if they are actually able to build the structure with the number of folders requested in their bid. This enhancement to the project would require each team to carefully plan the layout of structural members and gusset plates prior to submitting its bid—a good exercise in planning and geometry.